

Mixergy®

Installation and servicing instructions MDC0001

For stainless steel hot water cylinders

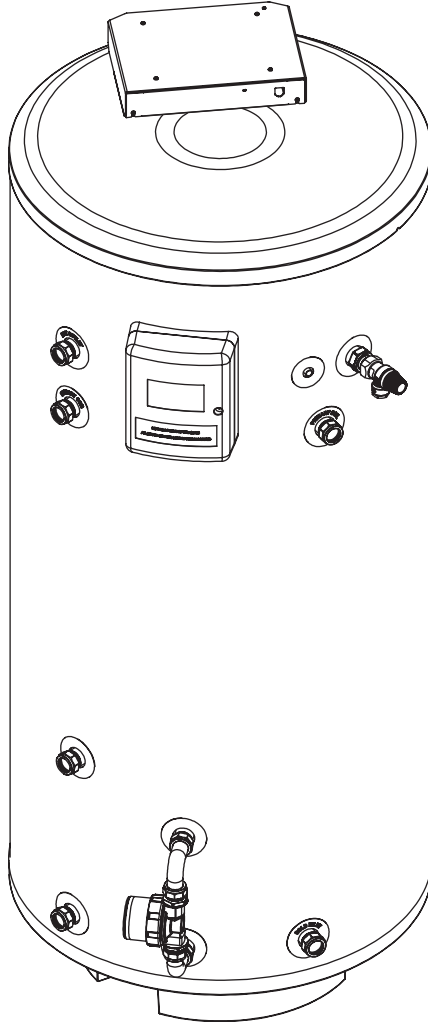

PLEASE LEAVE WITH HOUSEHOLDER

Failure to install and maintain this system in accordance with these instructions will invalidate the manufacturer's warranty.

V14 16/04/21

Cylinder details

MX number

Your cylinder MX number can be found on the label placed on the front of the cylinder.

For all queries, please contact us:

Tel: 01865 884343

E-Mail: enquiries@mixergy.co.uk

Technical data

Max. supply pressure to pressure reducing valve	1 MPa (10 bar)
Operating pressure	0.3 MPa (3 bar)
Expansion vessel charge pressure	0.3 MPa (3 bar)
Expansion relief valve setting	0.6 MPa (6 bar)
P&T relief valve setting (pressure)	0.7 MPa (7 bar)
P&T relief valve setting (temperature)	90 °C
Thermostat cut-out temperature	80 °C
Adjustable temperature range (digital)	50 - 65 °C
Coil max. working pressure (indirect)	0.35 MPa (3.5 bar)
Immersion heater(s) rating	230-240 V~ 2.7-3.0 kW
Immersion heater(s) specification	EN 60335-2-73
Immersion heater(s) type	356 mm Incoloy

Contents

Cylinder details	2
Technical data	2
Contents	3
About your cylinder	4
Additional components	5
Design notes	6
Schematic: Direct	7
Schematic: Indirect/Lite	8
Schematic: Heat pump	9
Installation: general guidelines	10
Installation: electrical	13
Installation: connectivity	19
Discharge pipework	21
Commissioning	26
Commissioning checklist	29
Problem solving	31
Draining the cylinder	33
Replacement parts	33
Servicing and maintenance	34
Service record	35

About your cylinder

The Mixergy cylinder is a hot water storage cylinder which uses thermal stratification on charge (direct and indirect) and discharge (direct, indirect, lite and heat pump).

This stratification technology allows the Mixergy cylinder to partially heat (or 'charge') the water, reducing heat losses, improving available renewable capacity and allowing for exploitation of smart tariffs.

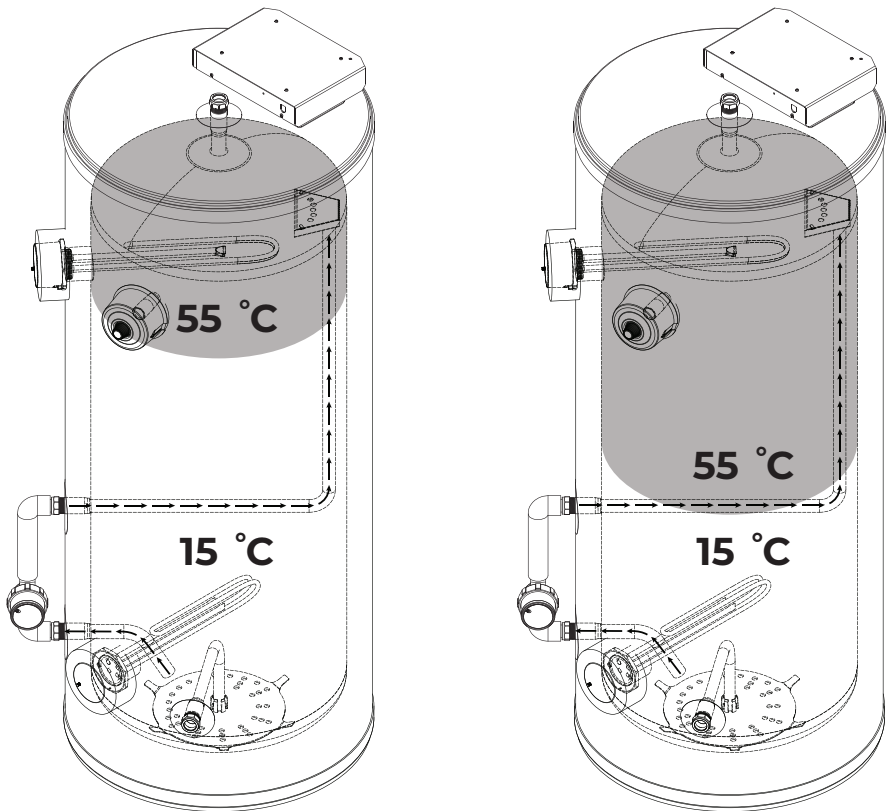

For more information on how your cylinder works and how to get the most out of your system, please refer to the user guide.

Additional components

- Monobloc kit incl. pressure reducing valve, check valve, pressure and temperature relief valve and expansion relief valve
- Tundish
- Expansion vessel incl. mounting bracket and 3/4" x 22mm adapters
- 3 kW immersion heater(s) 1.3/4" BSP (fitted)
- High limit thermostat (indirect only, fitted)
- 2-port diverter valve V4043H1056 (indirect only)
- Powerline to ethernet adapter TL-PA4010
- Ethernet cable
- User guide

Design notes

The Mixergy cylinder is currently available in four basic variations:

- Mixergy Direct - Provides hot water heated by electricity and is designed primarily for use with off peak electricity.
- Mixergy Indirect / Lite - Provides hot water either by electricity or an internal primary coil which is designed for use with electric, gas or oil fired boilers.

In addition, Mixergy cylinders can be fitted with the following options:

- Dual primary element for use with a third-party PV diverter.
- Embedded PV diverter.
- Heat pump exchanger module for use with heat pumps.



Unvented hot water cylinders must not be used with solid fuel boilers as the energy source.

All models are factory fitted / supplied with immersion heaters that have built-in thermal cut-outs. Immersion heaters without thermal cut-outs must not be fitted.

All unvented installations must be fitted with a pressure reducing valve (supplied) and P&T relief valve (fitted). These must not be removed or used for any other purposes than what they are designed for.

The unit should be handled with care in order to avoid damage. It should be stored upright in a dry place.

Schematic: Direct

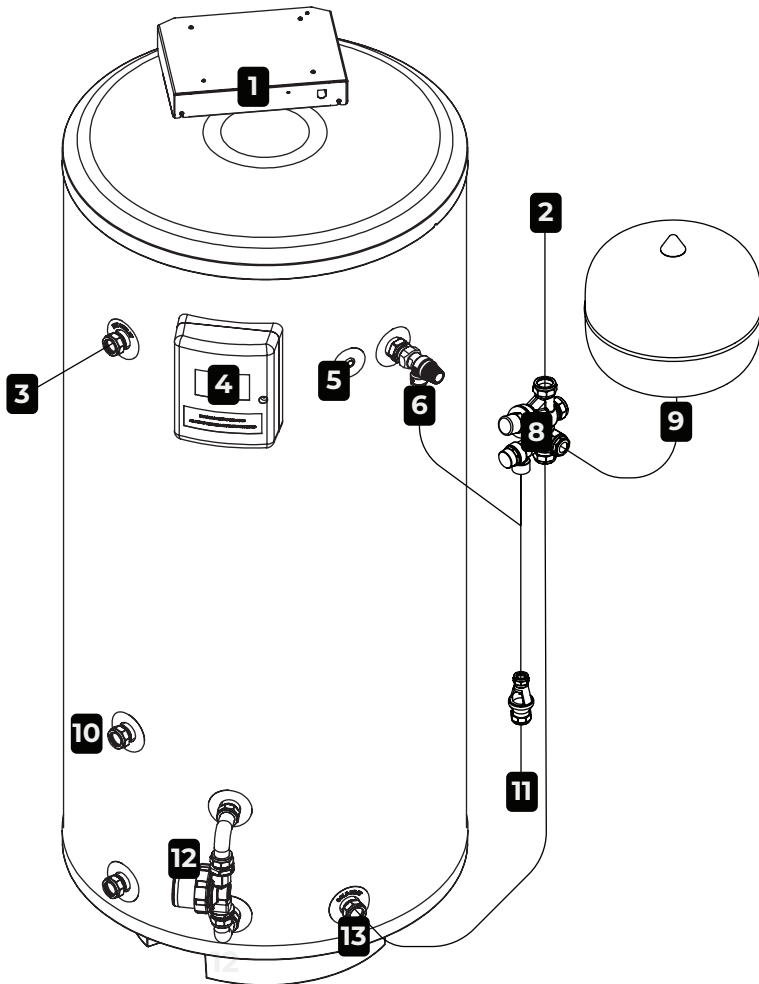

1	Controller	8	Cold water control monobloc
2	Cold feed	9	Expansion vessel
3	Hot draw	10	Heat pump exchanger ports
4	Primary immersion	11	Tundish and discharge pipe
5	External probe pocket	12	Pump assembly
6	P&T valve	13	Cold inlet
7	--	14	--

Schematic: Indirect/Lite

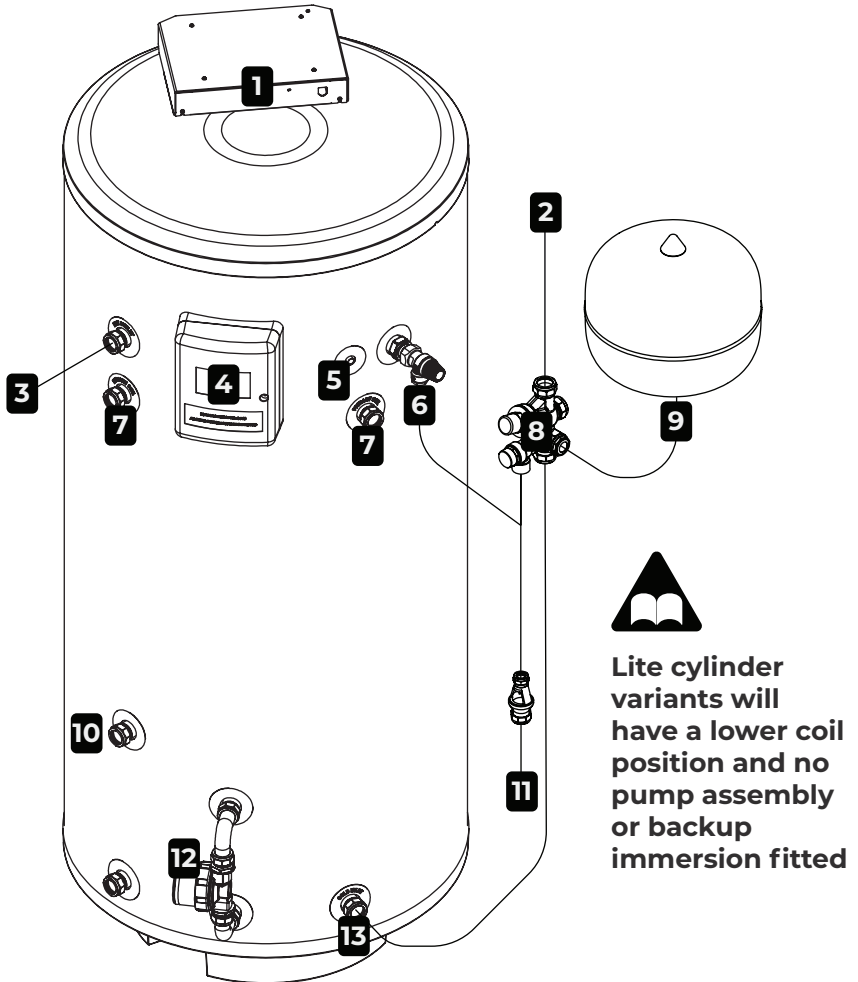

1	Controller	8	Cold water control monobloc
2	Cold feed	9	Expansion vessel
3	Hot draw	10	Heat pump exchanger ports
4	Primary immersion	11	Tundish and discharge pipe
5	External probe pocket	12	Pump assembly
6	P&T valve	13	Cold inlet
7	Indirect coil feed/return	14	--

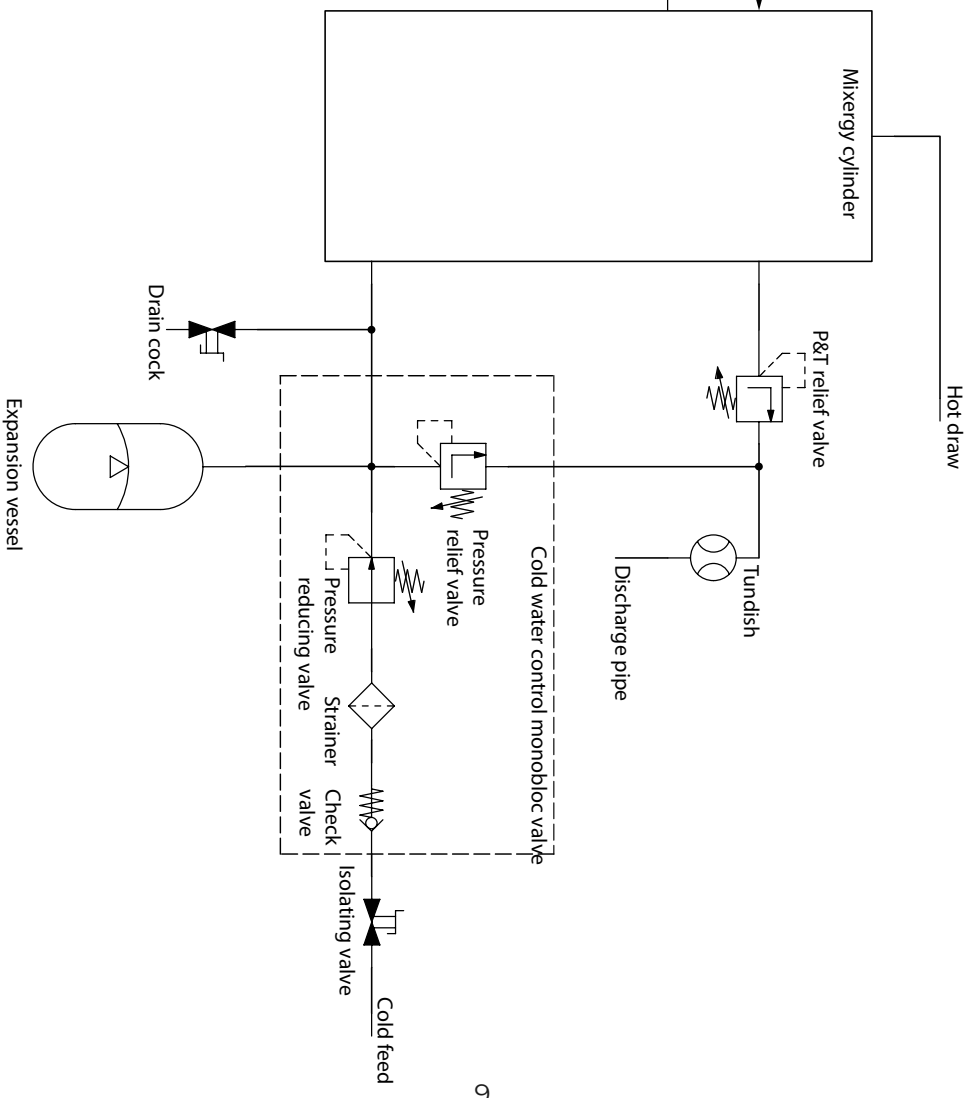
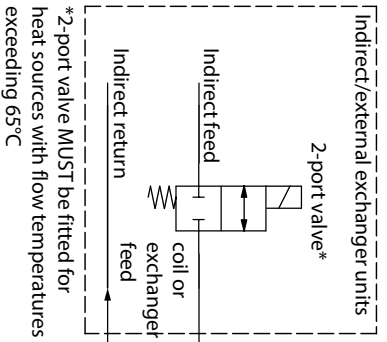

Installation: general guidelines



In the case of an unvented installation, install of this product should only be carried out by a “competent operative” i.e. the installer must have attended a recognised course in unvented hot water systems or received appropriate training in their apprenticeship. All registered operatives should carry an Identification Card issued by the institute of Unvented Hot Water Systems.

The installation area should be able to cope with the weight, incoming pipes and discharge pipe when full. Full weights are listed on page 5 of this booklet.

Positioning of the cylinder

Position of the cylinder should suit the installation; all connections should be to the front for ease of access. Ensure suitable space is left for access for repair and/or replacement of immersions and valves etc. **Ensure at-least 300mm of vertical clearance above the cylinder.** Refer to page 5 for cylinder heights and the diagram below for guidelines on space requirements:

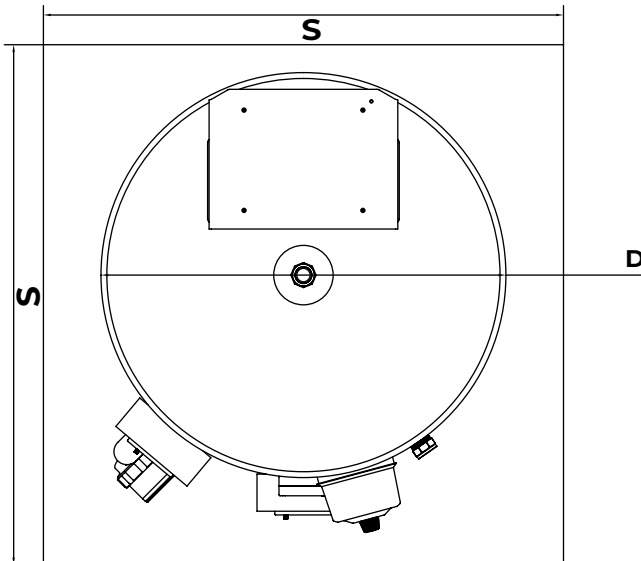

Ensure that any apertures (such as loft hatches) that the cylinder must pass through, meet the minimum space requirement S.

Nominal diameter nD (mm)	Space requirement S (mm)
470-480	580
550-580	700

Installation: general guidelines

Unvented installations

In the case of an unvented installation, installers should ensure incoming mains pressure is less than 1 MPa (10 bar) and at-least 0.1 MPa (1 bar) with a minimum flow rate of 5 L/min. Local authority approval for installation of unvented systems must be granted.

Use of flux and sterilisation

Excessive use of flux can damage the unit and especially the valves and expansion vessel (if supplied). Avoid over-use and ensure the system is fully flushed of any debris or flux after connection. If a full sterilisation of all the pipework including the cylinder is required then a complete drain down and flush of the unit is essential. A simple flush through with water is not adequate in removing all sterilising solution within the cylinder. Under no circumstances should sterilising solution be left in the cylinder any longer than required (seek dosage requirements from chemical manufacturer).

Pipework and cold water control group

The unit should be piped in with a nominal 22mm pipe to ensure adequate flow rate. The unit is supplied with a monobloc pressure reducing valve that has a set pressure of 3.0 bar. The valve also consists of a serviceable strainer, non return valve, expansion relief valve, connection for an expansion vessel and balanced cold feed supply. We would strongly recommend fitting an isolating valve (not supplied) prior to the monobloc valve for ease of maintenance at a later date. Under no circumstances should an isolating valve be fitted between the expansion valve and the storage cylinder.

Fitting a drain valve

Please ensure that a drain valve is fitted to the lowest part of the unit, The drain valve must be fitted as low as possible so that at least 80% of the cylinder's total capacity can be drained off.

Connecting the hot draw

It is recommended that a 90° elbow be fitted within 100 mm of the hot draw to minimize heat losses due to thermosiphoning.

Installation: general guidelines

Positioning the tundish

The tundish, which shows visible discharge from the relief valves, is to be in a prominent, visible and safe position away from any electrical devices. See discharge and safety devices on page 25.

Checking the P&T relief valve

The pressure and temperature relief valve is set at 7 bar and 90°C and is factory fitted and sealed prior to dispatch. Whilst we endeavour to make sure there are no leaks from the seal, we would advise checking the connection as the valve may have been disrupted in transit.

Fitting the expansion vessel

The expansion vessel should be checked and if required charged at 3.0 bar. The vessel should be mounted securely to the wall or sufficient support with the fixing kit supplied. The connection should be made between the vessel and monobloc kit.



The relief valves are only to be used for relief discharge purposes. No valves should be fitted between the relief valves and the cylinder.

Indirect units and electrical wiring

On Indirect units, where a coil is fitted to the cylinder, the supplied two port motorized zone valve must be fitted in accordance with the instruction details supplied for the appropriate installation. Maximum working pressure of the coils is 3.5 Bar. All electrical wiring to electronics, zone valve and immersion heaters must be earthed and to current IEE Wiring Regulations.



The electrical supply to the controller and any additional immersion heaters must be installed by a qualified electrician.

Installation: electrical



ENSURE ALL ELECTRICAL SUPPLIES ARE SWITCHED OFF BEFORE MAKING ANY CONNECTION TO THE UNIT. ELECTRICAL INSTALLATION MUST BE CARRIED OUT BY COMPETENT ELECTRICIAN AND BE IN ACCORDANCE WITH THE LATEST I.E.E. REGULATIONS.



External wiring

Mixergy cylinders come supplied with cable included. The purpose and installation requirements for each cable are given below. Layout of the internal junctions within the controller are also given should replacement cables be required.

Supply

The white 3-core (L,N,E) cable labelled 'supply' must be connected to the household's peak supply via a dedicated 16A MCB protected circuit with a 20A DP switch. This is the primary power supply for the control electronics and is used to power the immersion when the cylinder is set to heat in direct mode.

Timer control

The black 3-core (L,N,E) cable labelled 'timer control' can be used to integrate the Mixergy cylinder with any existing timers or controllers i.e. economy 7 timer or a hive controller. See 'External controller wiring' on page 17 for more details on wiring in an external controller. This cable detects a 240VAC signal and instructs the cylinder to heat unless otherwise disabled in software.

Indirect control

The white 4-core (COM, NO, NC, E) cable labelled 'indirect control' can be used to provide an indirect control signal for the purpose of making a call for heat to a boiler/heat pump. When the cylinder makes a call for heat in indirect/heat pump mode, the controller will switch the incoming supply at COM from NC to NO. This signal can be a maximum of 240VAC, 13A. For further details on indirect wiring please refer to "Indirect wiring" on page 14. For further details on heat pump wiring, please refer to manual MDC0008.



Both the timer control cable and indirect control cable are attached to volt free contacts within the controller and can be safely left tucked away if not required.

Indirect wiring

Mixergy indirect cylinders can be wired into both S-plan and Y-plan heating configurations. Please use the following instructions for reference.



These instructions are given as a generic reference, specific timer/smart controller and central heating valve wiring may vary.

Indirect and external controller wiring

Indirect cylinders are wired via the cable labelled 'indirect control'. Full schematics are given on page 15 and page 16. **All conductors of this cable must be safely terminated when an indirect installation is made.** If a direct installation is made it is recommended to leave this cable tucked away in case it is required for a subsequent heat pump installation.

Wiring with 2 port zone valve (S-plan)

- Connect a 3A fused supply live to the indirect control cable **BLACK**.
- Connect 3A supply neutral to both valves **BLUE**.
- Connect 3A supply earth to the indirect control cable **YELLOW/GREEN**.
- Connect the 2 port valve **BROWN** cable to the indirect control cable **BROWN**.

Wiring with 3 port mid position valve and 2 port zone valve (Y-plan)

- Connect a 3A fused supply live to the indirect control cable **BLACK**.
- Connect 3A supply neutral to both valves **BLUE**.
- Connect 3A supply earth to the indirect control cable **YELLOW/GREEN**.
- Connect the 2 port valve **BROWN** cable to the indirect control cable **BROWN**.
- Connect the 3 port valve **GREY** cable to the indirect control cable **GREY**.
- Connect the 3 port valve **ORANGE** cable to the 2 port valve **ORANGE** cable.

Installation: electrical (S-PLAN)

S-PLAN SCHEMATIC VIEW

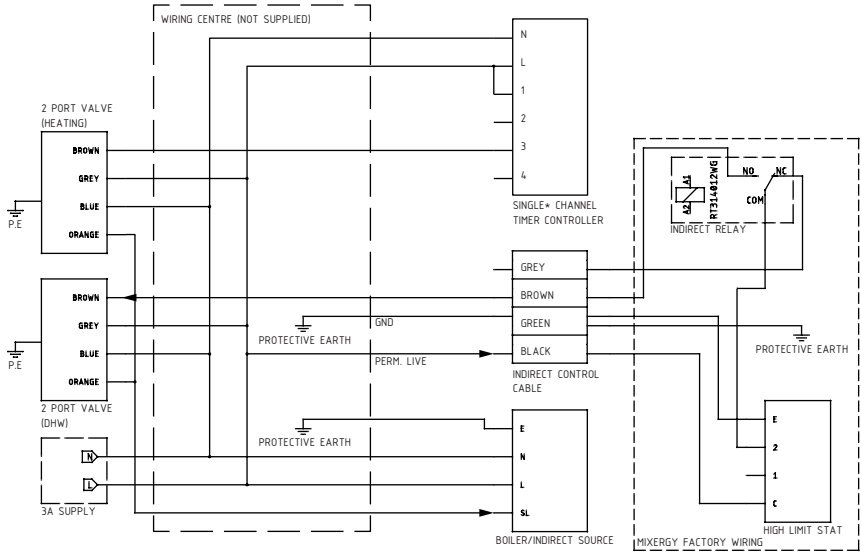

S-PLAN PICTORAL VIEW

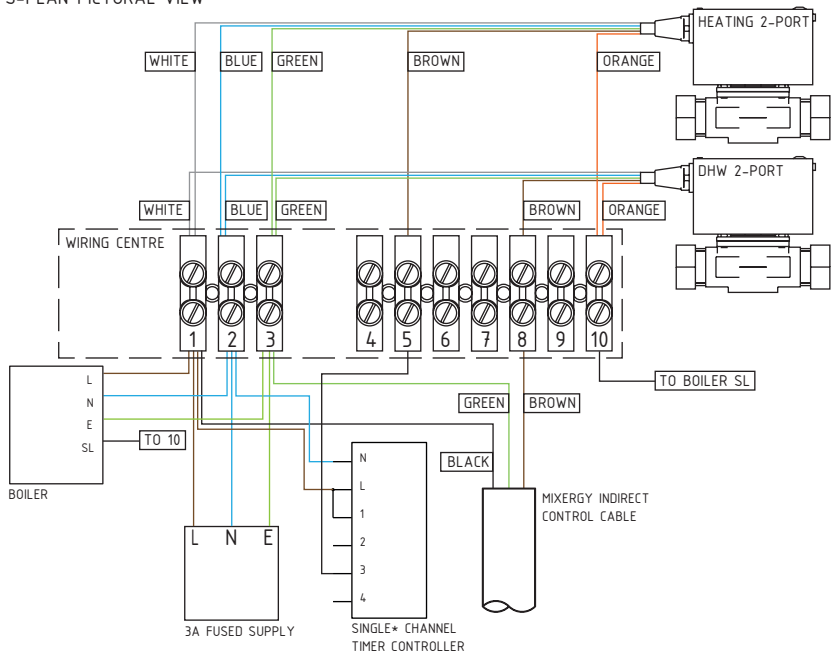

***In the case of a dual channel timer controller, connect timer terminal 4 to terminal 5 of the wiring centre. Connect terminal 3 to timer control cable if required (page 17)**

Installation: electrical (Y-Plan)

Y-PLAN SCHEMATIC VIEW

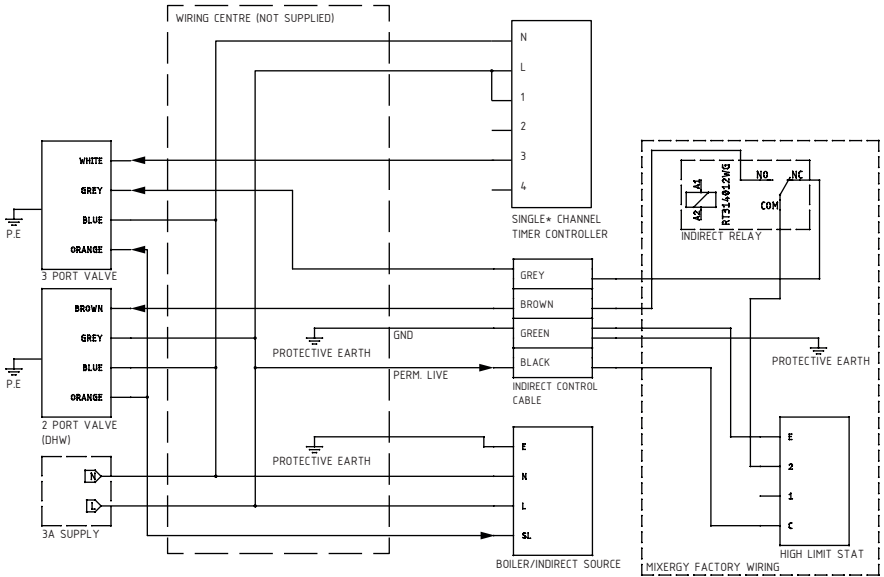

Y-PLAN PICTORAL VIEW

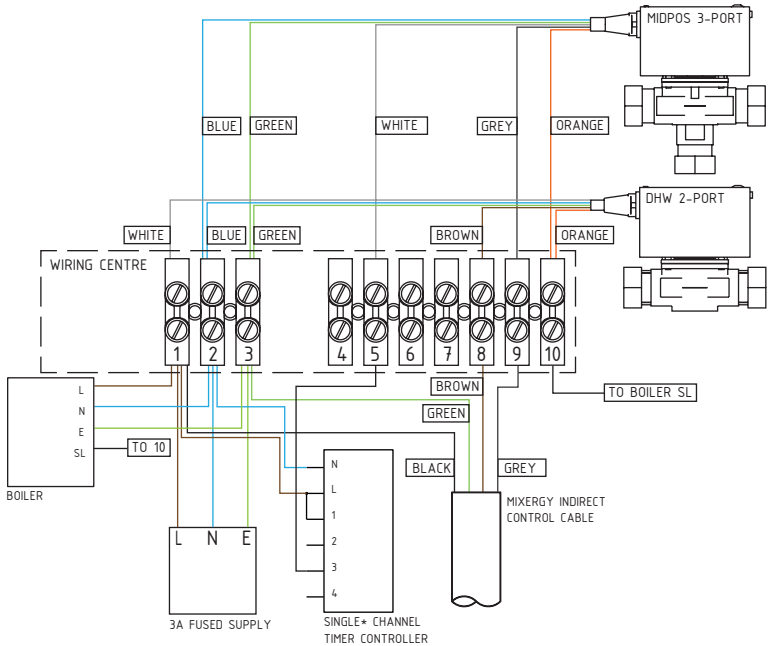

***In the case of a dual channel timer controller, connect timer terminal 4 to terminal 5 of the wiring centre. Connect terminal 3 to timer control cable if required (page 17)**

Installation: electrical

External controller wiring

Mixergy systems can be connected to an external controller using the timer control cable as follows:

- Connect the brown (L) cable to the external controller 'DHW ON' junction.
- Connect the blue (N) cable to external controller neutral.
- Connect the yellow/green (E) cable to ground.

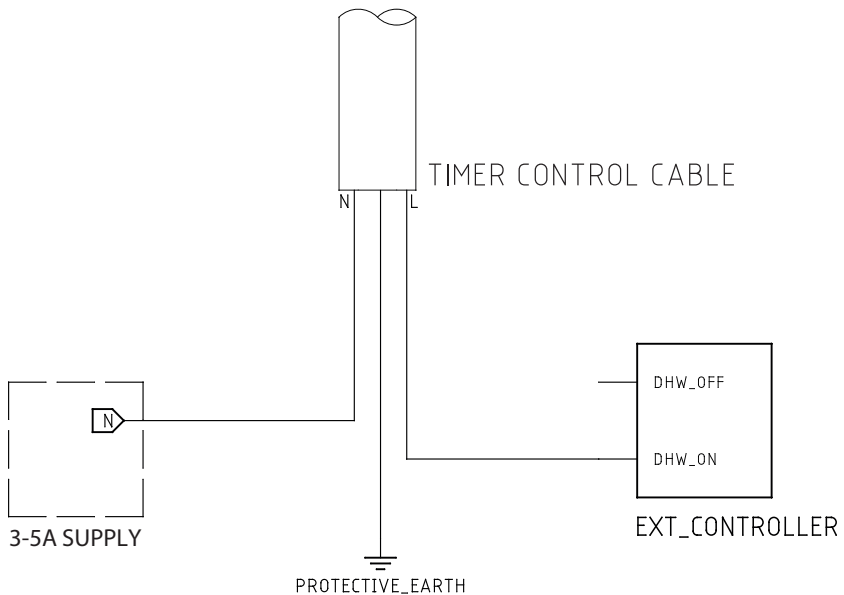

The timer control cable should only be connected when the user does not wish to control their system using the Mixergy app.

The timer control cable is not required if the user wishes to control via the Mixergy app.

Installation: electrical

PV diverters

If your Mixergy cylinder is equipped for use with a third-party PV diverter, a dual immersion will be fitted to replace the primary immersion shown in the schematics on page 7 and page 8. This immersion will come factory wired into the Mixergy system with an additional 3-core (L+N+E) cable labelled 'solar feed' that should be wired into your PV diverter as specified by the manufacturer. If a replacement cable is required, please use the wiring diagram below for reference.

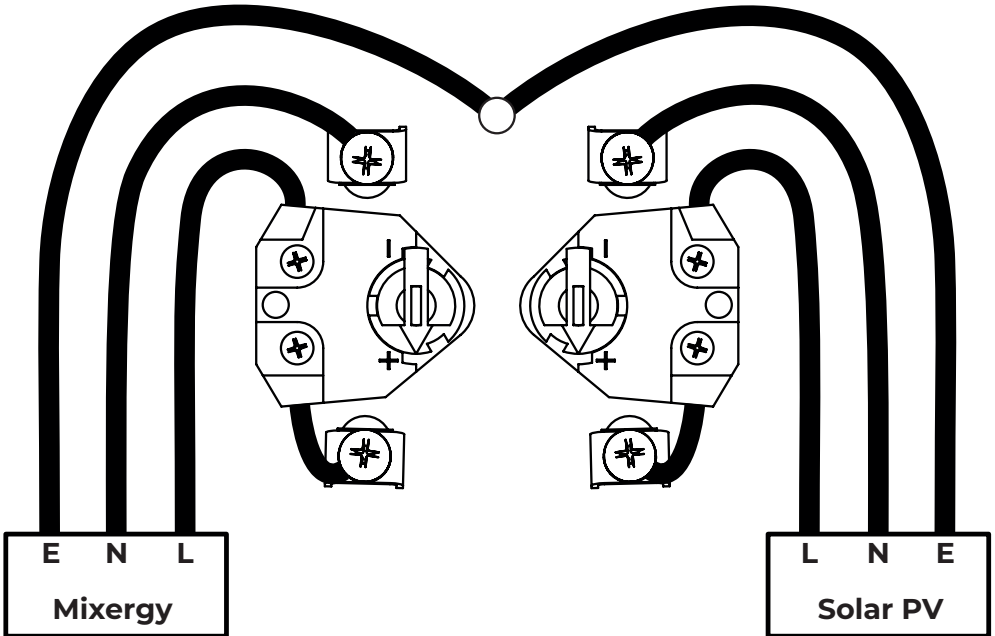

Ensure both supplies are isolated before performing work. Check continuity between immersion contacts before wiring. DO NOT CONNECT SOLAR PV AND MAINS LIVE OR NEUTRAL TOGETHER.

Installation: connectivity

Installing the powerline adapter

The Mixergy cylinder requires internet connectivity to allow for full control of the system. Connection to the cylinder can be made using the provided ethernet to powerline adapter.



If an existing HomePlug AV powerline network is installed at the property, it is recommended to pair the cylinder with the existing network to avoid interference problems as per page 28. Powerline connectivity between the cylinder and internet router is only possible in houses where both the cylinder and adapter are powered from the same electrical phase.

1. Plug the powerline adapter into a wall socket within 2m of the internet router.
2. Plug the powerline adapter into the internet router using the included 2m ethernet cable.

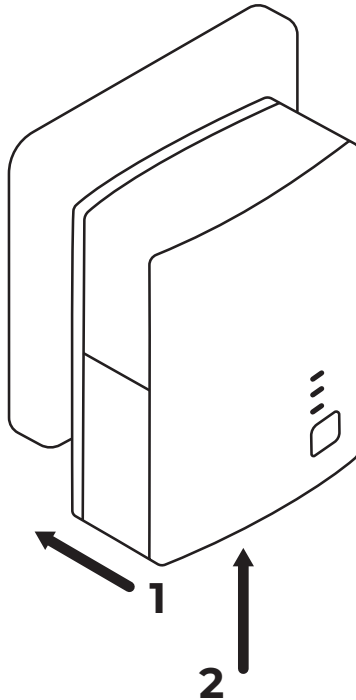

Installation: connectivity

Hardwiring an ethernet connection

If a hardwired CAT5/CAT5e/CAT6 connection is desired, this is achievable by removing the blue ethernet cable from the port pictured, this can then be replaced with a provided ethernet cable for a wired internet connection.

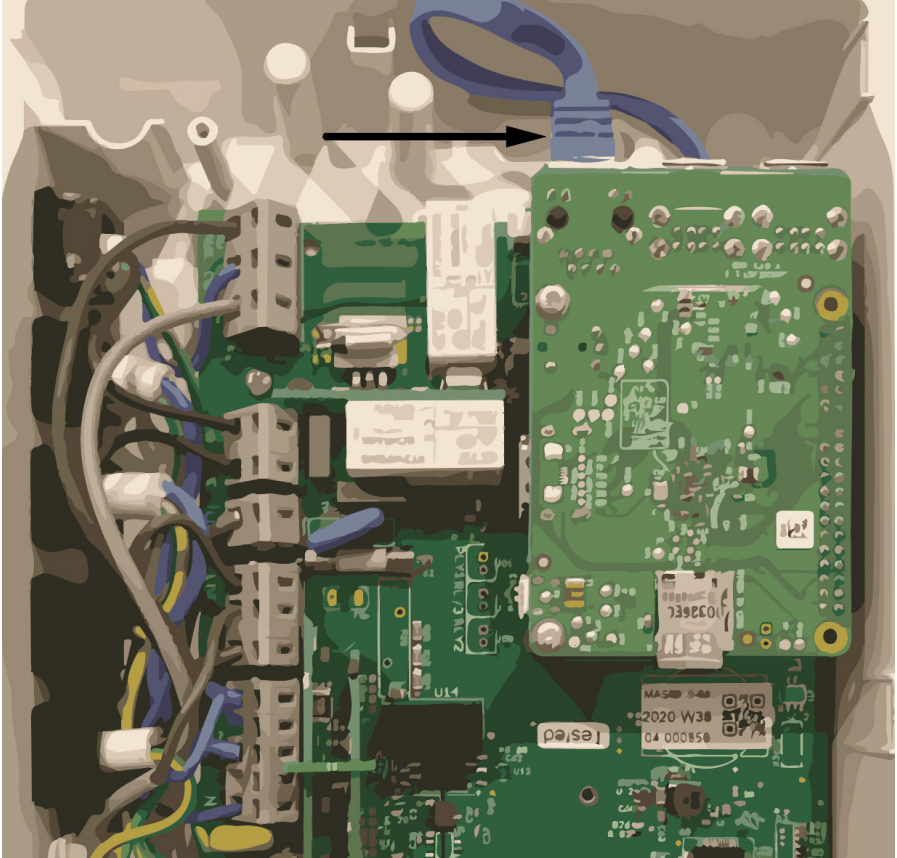

Discharge pipework

Discharge pipes from safety devices

- Safety devices such as temperature relief valves or combined temperature and pressure relief valves should discharge either directly or by way of a manifold via a short length of metal pipe (D1) to a tundish.
- The diameter of discharge pipe (D1) should be not less than the nominal outlet size of the safety device, e.g. temperature relief valve.
- Where a manifold is used it should be sized to accept and discharge the total discharge from the discharge pipes connected to it.
- Where valves other than a temperature and pressure relief valve from a single unvented hot water system discharge by way of the same manifold that is used by the safety devices, the manifold should be factory fitted as part of the hot water storage system unit or package.

Tundish

- The tundish should be vertical, located in the same space as the unvented hot water storage system and be fitted as close as possible to, and lower than, the safety device, with no more than 600mm of pipe between the valve outlet and the tundish. Note: to comply with the Water Supply (Water Fittings) Regulations, the tundish should incorporate a suitable air gap.
- Any discharge should be visible at the tundish. In addition, where discharges from safety devices may not be apparent, e.g. in dwellings occupied by people with impaired vision or mobility, consideration should be given to the installation of a suitable safety device to warn when discharge takes place, e.g. electronically operated.

Discharge pipework

Typical discharge pipe arrangement

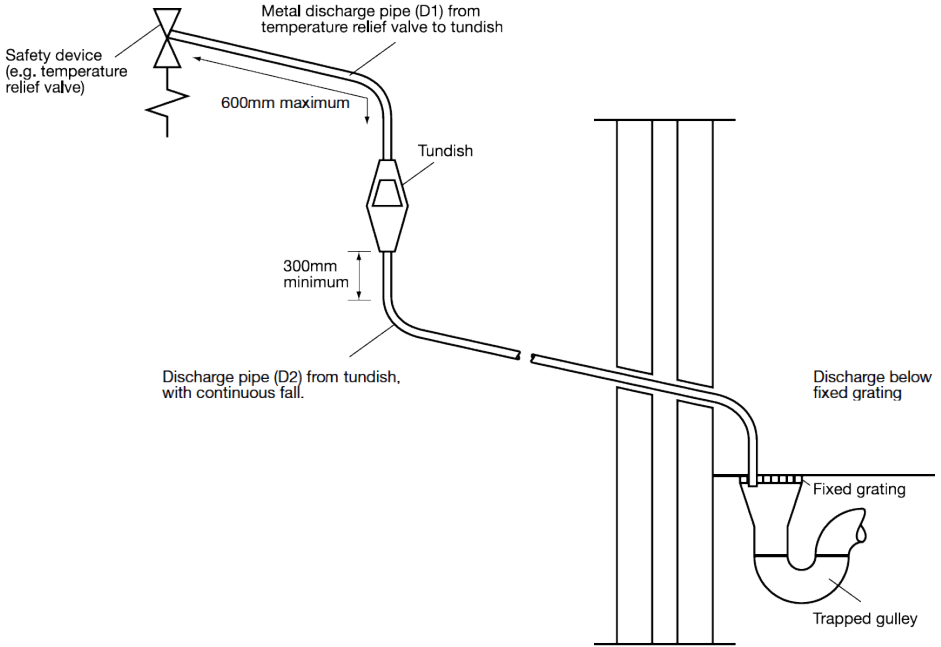

Sizing of copper discharge pipe 'D2' for common temperature relief valve outlet sizes

Valve outlet size	Minimum size of discharge pipe D1	Minimum size of discharge pipe D2 from tundish	Maximum resistance allowed, expressed as a length of straight pipe	Resistance created by each elbow or bend
G 1/2"	15 mm	22 mm	< 9 m	0.8 m
		28 mm	< 18 m	1.0 m
		35 mm	< 27 m	1.4 m
G 3/4"	22 mm	28 mm	< 9 m	1.0 m
		35 mm	< 18 m	1.4 m
		42 mm	< 27 m	1.7 m
G 1"	28 mm	35 mm	< 9 m	1.4 m
		42 mm	< 18 m	1.7 m
		54 mm	< 27 m	2.3 m

Discharge pipework

Discharge pipe D2

- The discharge pipe (D2) from the tundish should have a vertical section of pipe at least 300mm long below the tundish before any elbows or bends in the pipework. It should be installed with a continuous fall of at least 1 in 200.
- The discharge pipe (D2) should be made of metal or other material that has been demonstrated to be capable of safely withstanding temperatures of the water discharged and is clearly and permanently marked to identify the product and performance standard (e.g. as specified in the relevant part of BS 7291-1:2006.)
- The discharge pipe (D2) should be at least one pipe size larger than the nominal outlet size of the safety device unless its total equivalent hydraulic resistance exceeds that of a straight pipe 9m long, i.e. for discharge pipes between 9m and 18m the equivalent resistance length should be at least two sizes larger than the nominal outlet size of the safety device; between 18 and 27m at least 3 sizes larger, and so on; bends must be taken into account in calculating the flow resistance.
- Where a single common discharge pipe serves more than one system, it should be at least one pipe size larger than the largest individual discharge pipe (D2) to be connected.



An alternative approach for sizing discharge pipes would be to follow Annex D, section D.2 of BS 6700:2006 + A1:2009 Specification for design, installation, testing and maintenance of services supplying water for domestic use within buildings and their curtilages.

Discharge pipework

- The discharge pipe should not be connected to a soil discharge stack unless it can be demonstrated that the soil discharge stack is capable of safely withstanding the temperatures of the water discharged, in which case, it should contain a mechanical seal, not incorporating a water trap, which allows water into the branch pipe without allowing foul air from the drain to be ventilated through the tundish.
- If plastic pipes are used as branch pipes carrying discharge from a safety device, they should be either polybutylene (PB) or cross-linked polyethylene (PE-X) complying with national standards such as Class S of BS 7291-2:2006 or Class S of BS 7291-3:2000 respectively; and be continuously marked with a warning that no sanitary appliances should be connected to the pipe.
- Where pipes cannot be connected to the stack it may be possible to route a dedicated pipe alongside or in close proximity to the discharge stack.



Plastic pipes should be joined and assembled with fittings appropriate to the circumstances in which they are used as set out in BS EN ISO 1043-1:2002.

Discharge pipework

Termination of discharge pipe

The discharge pipe (D2) from the tundish should terminate in a safe place where there is no risk to persons in the vicinity of the discharge.

Examples of acceptable discharge arrangements are:

To a trapped gully with the end of the pipe below a fixed grating and above the water seal.

- Downward discharges at low level; i.e. up to 100mm above external surfaces such as car parks, hard standings, grassed areas etc. are acceptable providing that a wire cage or similar guard is positioned to prevent contact, whilst maintaining visibility.
- Discharges at high level: e.g. into a metal hopper and metal downpipe with the end of the discharge pipe clearly visible or onto a roof capable of withstanding high temperature discharges of water and 3 m from any plastic guttering system that would collect such discharges.



DO NOT SWITCH THE SYSTEM ON UNLESS THE CYLINDER IS COMPLETELY FILLED WITH WATER.

All factory fitted valves etc. are fitted using a thread sealant. If this seal is broken it should be re-sealed using a suitable sealant. It is the installer's responsibility to ensure all the connections are water tight prior to leaving the property.

1. Ensure the drain on the cold feed pipework is closed.
2. Open a hot tap the furthest distance from the unit.
3. Gradually open the cold mains isolator valve and fill cylinder until water appears at the hot tap. Attend to each hot water outlet in turn and ensure water flow is obtained at each outlet expelling any air within the pipework.
4. To ensure the safety valves are operating correctly, turn the tops of the valves independently to ensure water passes through the valve and into the tundish. Once this is confirmed, open both valves together allowing as much water as possible to flow through the tundish. At this point make sure that your discharge pipework is free from debris and is transporting the water away to waste effectively. The valves can then be released and a check should be made to ensure they have re-seated correctly.
5. Switch on the Mixergy cylinder and check for correct operation. Mixergy cylinders come supplied in 'eco mode' which is designed to satisfy the minimum charge requirements of BS EN 50440:2015 M draw profile. Pressing any button on the gauge twice will exit eco mode. To re-enable eco mode, hold down boost -and power buttons simultaneously for 10 seconds.
6. Connect the cylinder to the internet by pairing to the included powerline adapter. For more information on pairing the cylinder to the adapter, please reference page 28.



Ensure the cylinder's gauge illuminates and all buttons (boost -, boost + and power) work correctly. For further information on gauge operation please reference the user guide.

Changing heat sources

All Mixergy systems leave the factory in direct operation, in the case of a heat pump or indirect installation, the cylinder's primary heat source must be switched to indirect to allow for operation of the 2 port valve and boiler. This can be achieved in a number of ways:

1. In the case where the cylinder has been commissioned and an internet connection has been established, the primary heat source can be changed by the installer using the Mixergy Enterprise Installer app or by the user via the standard Mixergy app. Please refer to the respective app guides for further guidance.
2. In the case where an internet connection could not be made to the cylinder during commissioning, the primary heat source can be set by holding the boost + and boost - buttons simultaneously until the entire display is lit white. To change the heat source, let go of the buttons once the display has changed to the required colour (BLUE for direct, RED for indirect and GREEN for heat pump).



Please note that any heat source that is set while the cylinder is offline will be overwritten once the cylinder establishes an internet connection, please ensure that the default heat source is set correctly on the app once the system is fully connected.

Status LED error codes

If the system is not behaving as expected, please check the status LED on the front of the controller enclosure and contact Mixergy:

1. **Flashing green:** system OK
2. **Solid green/red:** system updating (DO NOT REMOVE POWER)
3. **Very slow flashing red (once every two seconds):** temp. sensor problem
4. **Slow flashing red (once a second):** no gauge detected
5. **Fast flashing red (twice a second):** energy measurement issue
6. **Very fast flashing red (five times a second):** main processor issue

Commissioning

Pairing the cylinder and connecting to the internet

In the case that the cylinder does not automatically pair to the powerline adapter or connection to an existing homeplug AV network is desired, please follow the steps below to pair the cylinder to the network.

1. Remove the small screw from the pairing hole located in the rear right corner of the controller.
2. Use a thin tool to depress and hold the pair button for 1 - 2 seconds.
3. Depress the pair button on the powerline adapter for 1-2 seconds within 2 minutes of step 2.
4. Observe all 3 LEDs as solid green on the powerline adapter.

Ensure the screw is replaced in the pairing hole once pairing is completed.



The cylinder must be registered and connected online in order to validate the manufacturer's 25 yr warranty.

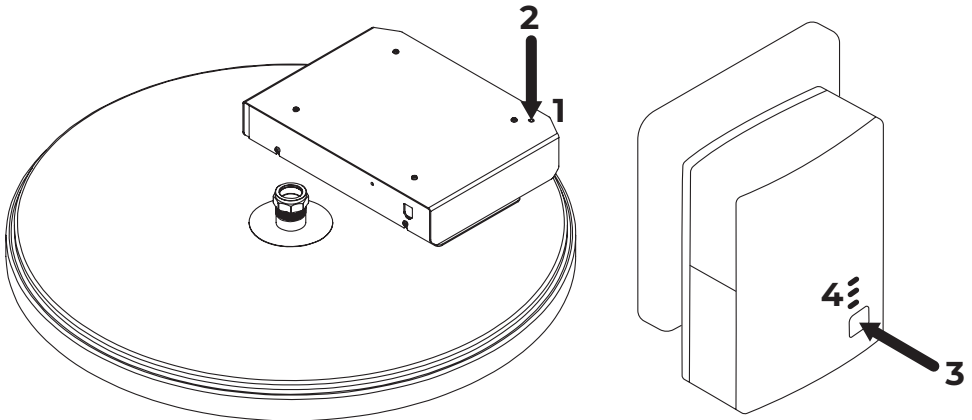

Commissioning checklist

This Commissioning Checklist is to be completed in full (either in this booklet or on the side of the cylinder) by the competent person who commissioned the cylinder as a means of demonstrating compliance with the appropriate Building Regulations.

Failure to install and commission this equipment to the manufacturer's instructions may invalidate the warranty but does not affect statutory rights.

Please ensure all information is filled in correctly below.

Fitter details	
System ID no.	
Commissioned by	
Registration operative no.	
Approval licence no.	
Company name	
Company address	
Commissioning date	
Telephone no.	
Building regulations notification no.	

Commissioning checklist

Cylinder primary settings

Is the circuit sealed or vented?

Set system pressure

bar

Unvented cylinders only

Has a P&T relief valve and expansion relief valve been fitted and discharge tested?

Is a cut-out device fitted?

Pressure reducing valve setting

bar

Has the expansion vessel been checked?

Final checks

The cylinder has been filled with water, correctly wired into a 16A fused spur and powered on

The functionality of the system (including indirect wiring) has been checked and verified

The cylinder has been connected to the internet and the customer has been registered online

The cylinder controls have been demonstrated to and understood by the customer

The manufacturer's literature, has been explained and left with the customer

Commissioning engineer's signature

Customer's signature

Date

/ /

Problem solving



Discharge from either of the relief valves indicates a malfunction in the system and must be investigated immediately.

Overheated water

In the unlikely event of overheated (95°C) water being discharged, the Mixergy controller should be switched off immediately and a competent engineer called out. Please contact Mixergy directly.



Do not shut off the cold water supply to the unit.

Water discharge

If water is occasionally being discharged during heating, this likely indicates that the Expansion Vessel needs to be recharged. In the event of this occurring, switch off all power supplies to the cylinder, and re-charge the vessel. If water is continually being discharged, firstly check with a gauge that the pressure allowed through the PRV does not exceed 3 bar. If it does exceed 3 bar then the valve should be stripped, cleaned and inspected. Should a replacement be required then only one supplied by Mixergy should be used.

Electrical fault

If an electrical fault of the controller is suspected or the electrical system does not operate as expected, please contact Mixergy directly.

Connectivity issues

If a connectivity issue is suspected, please refer to the User Guide and FAQs for guidance.

Expansion vessel check and re-charging

Check pressure via the Schrader valve on top of the vessel which is situated under the removable plastic cap. The vessel can be checked and recharged by switching off the stopcock or isolating the water supply to the cylinder, then opening a hot tap to deplete the pressure inside the cylinder. Unscrew the black plastic cap on the expansion vessel to reveal the Schrader valve, with the aid of a pressure gauge ensure the pressure reads 3.0 bar. If there is insufficient pressure within the vessel, top up the vessel via a pump and recharge to 3.0 bar.

Safety valves

If all previous checks have been done and water is still being discharged from either safety valve, determine which valve is faulty and replace one supplied by Mixergy.

Cross flow

If all the valves have been replaced and the vessel re-commissioned then the system could be suffering from cross flow, this is when the hot and cold systems are not balanced and higher pressure cold water is forced back into the cylinder. If this is the case then an additional pressure-reducing valve may be required to reduce the cold water supply pressure.

Immersion heaters

If the immersion heater is not heating the water adequately it has either failed (in which case a replacement immersion heater as supplied by Mixergy should be fitted), an electrical fault is present or the electrical cut-out has operated due to the control thermostat being set too low or being faulty. Activate the reset button under the immersion cover. If the problem persists please contact Mixergy directly.

Draining the cylinder

1. Switch off the immersion heater(s), boiler and any other heat sources.
2. Switch off water at mains.
3. Open nearest hot tap.
4. Open drain to start draining the cylinder.

To re-fill follow the commissioning instructions.

Flushing the cylinder

To flush out the system, drain the unit as above, fill and repeat. If after recharging the expansion vessel the cylinder is still discharging, it may be due to cross-flow - ensure appropriate check valves are fitted. The pressure reducing valve, one of the relief valves, or the expansion vessel may have failed. The component should be identified and replaced by one supplied by Mixergy Ltd.

Replacement parts

Do not attempt to repair or replace any parts of the Mixergy cylinder unless you are a trained operative. If you suspect a fault or a replacement part is needed, please contact Mixergy directly.

To determine the correct parts for your system, please ensure you have your cylinder MX number which can be found on the nameplate located at the front of the cylinder.

Part description	Part no.
Immersion stat	MEL0018
Immersion heater (dual solar)	MEL0019
Pump assembly	MAS0002
Controller	MAS0005
Gauge	MAS0021
Indirect stat	MEL0027
2-port valve	MEL0023
Heat pump exchanger	MME0072

ANNUAL MAINTENANCE should be performed by a competent operative.

Failure to maintain this system in accordance with these instructions will invalidate the manufacturer's warranty. A maintenance record should be kept on the service record on page 35 of this booklet. We would recommend a service program is arranged on installation. Failure to maintain this record will invalidate the manufacturer's warranty.

Annual service checks

- Expansion relief valve– manually open the twist cap and check that the water is discharged and runs clearly through the Tundish and out at the final discharge point. Ensure that the valve re-seats/re-seals itself.
- Pressure & temperature relief valve - repeat the above procedure. Ensure that the valve re-seats/re-seals itself.
- Strainer - turn off mains at stopcock. There will be a small amount of residual water in the pipework, remove the cartridge from Pressure Reducing Valve, clean Strainer and replace.
- Expansion vessel - check pressure via the valve on top of the vessel which is located under the plastic cap. Ensure pressure is 3 Bar. Vessel can be recharged if required as per "Expansion vessel check and re-charging" on page 32.

Disassociating an account

If a new tenant is moving into the property and the user of the account tied to the cylinder needs to be changed, the new tenant will have to disassociate the cylinder from the existing account before registering. This can be performed by pressing and holding the boost down and power buttons for approximately 15 seconds.

Mixergy Ltd

2 Canal View, Wharf Farm, Eynsham Road, Cassington, Oxfordshire, OX29 4DB

01865 884343

enquiries@mixergy.co.uk