

# LG

**THERMA V™**

Air-to-Water Heat Pump / Split Type (High Temp.)

R410A/R134a (50Hz)

5BPU0-01C(Replaces 5BPU0-01B)

# TOTAL HVAC

# SOLUTION

# PROVIDER

## ENGINEERING PRODUCT DATA BOOK

***THERMA V***<sup>TM</sup>

Split Type

**General Information**

**Indoor Unit**

**Hydro Box Unit**

**Outdoor unit**

***THERMA V***<sup>TM</sup>  
Split Type

**General Information**

- 1. Model Line Up**
- 2. Nomenclature**

# 1. Model line up

## 1.1 Indoor Unit (Hydro Box Unit)

Type	Type	Heating Capacity (kW)	External Appearance	Model Name
AWHP Split Type High Temperature	Hydro Box Type	16.0		AHNW166T3 [HN1610H NK3]

## 1.2 Outdoor Unit

Power Supply	Heating Capacity (kW)	External Appearance	Model Name
1 Phase Model 1 Ø, 220-240 V, 50 Hz	16.0		AHUW166T3 [HU161HA U33]

## 2. Nomenclature

### 2.1 Indoor Unit

#### ■ Factory Model Name

<b>Model Name</b>	<b>AH</b>	<b>N</b>	<b>W</b>	<b>16</b>	<b>6</b>	<b>T</b>	<b>3</b>
No.	1	2	3	4	5	6	7

No.	Signification
1	<b>Air-to-Water Heat Pump for R410A</b>
2	<b>Classification</b> N : Indoor unit of Split type
3	<b>Model Type</b> W : Inverter Heat Pump
4	<b>Heating Capacity (kW)</b> Ex) 16kW → '16'
5	<b>Electrical ratings</b> 6 : 1Ø, 220-240V, 50 Hz
6	<b>Function</b> T : High temperature heating heat pump
7	<b>Serial number</b>

## 2. Nomenclature

### ■ Buyer Model Name

<b>Model Name</b>	<b>H</b>	<b>N</b>	<b>16</b>	<b>1</b>	<b>0</b>	<b>H</b>	<b>.</b>	<b>N</b>	<b>K</b>	<b>3</b>
No.	1	2	3	4	5	6		7	8	9

No.	Signification
1	<b>Air-to-Water Heat Pump</b>
2	<b>Classification</b> N : Indoor unit of Split type
3	<b>Heating Capacity (kW)</b> Ex) 16kW → '16'
4	<b>Electrical ratings</b> 1 : 1Ø, 220-240V, 50 Hz
5	<b>Nominal Heating Capacity</b> 0 : None Heater
6	<b>Leaving Water Combination</b> H : High temperature Leaving Water
7	<b>Classification</b> N : Indoor unit of Split type
8	<b>Platform (Chassis code)</b> K : K3 Chassis
9	<b>Serial number</b>

## 2. Nomenclature

### 2.2 Outdoor Unit

#### ■ Factory Model Name

<b>Model Name</b>	<b>AH</b>	<b>U</b>	<b>W</b>	<b>16</b>	<b>6</b>	<b>T</b>	<b>3</b>
No.	1	2	3	4	5	6	7

No.	Signification
1	<b>Air-to-Water Heat Pump for R410A</b>
2	<b>Classification</b> U : Outdoor unit of Split type
3	<b>Model Type</b> W : Inverter Heat Pump
4	<b>Heating Capacity (kW)</b> Ex) 16kW → '16'
5	<b>Electrical ratings</b> 6 : 1Ø, 220-240V, 50 Hz
6	<b>Function</b> T : High temperature heating heat pump
7	<b>Serial number</b>

## 2. Nomenclature

### ■ Buyer Model Name

<b>Model Name</b>	<b>H</b>	<b>U</b>	<b>16</b>	<b>1</b>	<b>H</b>	<b>A</b>	.	<b>U</b>	<b>3</b>	<b>3</b>
No.	1	2	3	4	5	6		7	8	9

No.	Signification
1	<b>Air-to-Water Heat Pump</b>
2	<b>Classification</b> U : Outdoor unit of Split type
3	<b>Heating Capacity (kW)</b> Ex) 16kW : '16'
4	<b>Electrical ratings</b> 1 : 1Ø, 220-240V, 50 Hz
5	<b>Leaving Water Combination</b> H : High temperature Leaving Water
6	<b>Type of Refrigerant</b> A : R410A
7	<b>Classification</b> U : Outdoor unit of Split type
8	<b>Platform (Chassis code)</b> 3 : U60A Chassis
9	<b>Serial number</b>



***THERMA V***<sup>TM</sup>  
Split Type

**Indoor Unit**

**Hydro Box Unit**

# ***THERMA V***<sup>TM</sup>

Split Type

## **Hydro Box Unit**

- 1. List of Functions**
- 2. Specification**
- 3. Dimensions**
- 4. Wiring Diagrams**
- 5. Piping Diagrams**
- 6. Head loss by Water flow**
- 7. Operation Range**
- 8. Sound Levels**

# 1. List of Functions

## Basic functions of Unit

Category	Functions	AHNW166T3 [HN1610H NK3]
Installation	Backup heater	X
Reliability	Self diagnosis	O
Convenience	Auto Restart	O
	Child lock	O
	Sleep mode	O
	Timer (on/off)	O
	Timer (weekly)	O
	Two thermistor control	X
Network function	Network solution(LGAP)	O
Air to Water Heat Pump Functions	Anti-condensation on floor (cooling)	X
	Digital output for external pump	O
	Flow switch	O
	Thermostat interface (230V AC)	O
	Thermostat interface (24V AC)	X
	DHW(Domestic Hot Water) tank installation kit	X
	Therma V solar kit	X
	PHEX anti-freezing control	O
	Water pump anti-stuck function	O
	Weather compensation for heating and cooling (Auto mode)	O
	Low noise operation	X
	Anti-overheating of water pipe	O
	Emergency operation	O
	Weather Dependent Operation with Thermostat	X
	Scheduler (DHW Tank Heater)	X
	Timer (Domestic Hot Water Tank Heater)	X
	Quick Domestic Hot Water Tank Heating	X
	Screed Drying Mode	X
	Sump Heater	X
	Base Pan Heater	O
Integrated Dry Contact (CN-EXT)	O	

**Note**

1. O : Applied, X : Not applied

Accessory : Ordered and purchased separately the accessory package referring to the model name provided and install at field.

Accessory line-ups varies by region, so check your local catalogue or local sales material.

# 1. List of Functions

## ■ Accessory Compatibility List

Category		Product	Remark	AHNW166T3 [HN1610H NK3]
Wired Remote Controller	Standard	PREMTW101	New standard (White)	O
Dry Contact	Simple Contact	PDRYCB000	Simple Dry Contact	O
	Communication Type	PDRYCB400	2 Points Dry Contact (For Setback)	X
		PDRYCB300	For 3rd party Thermostat	O
		PDRYCB500	Dry Contact for Modbus	X
ETC	Remote temperature sensor	PQRSTA0	Wire : 15 m	O
	Group control wire	PZCWRCG3	0.25 m	X
	2-Remo Control Wire	PZCWRC2	0.25 m	O
	Extension wire	PZCWRC1	10 m	O
	Wi-Fi controller *	PWFMD200	USB Cable : 0.6 m Extension cable : 0.5 m	O
	Wi-Fi Extension cable	PWYREW000	USB Extension cable : 10 m	O
	Meter Interface Module ***	PENKTH000	Interface between IDU and Meter	O
	Modbus RTU	PMBUSB00A	-	O
Accessory Kit for AWHP	DHW tanks (Single coil)	OSHW-200F	200 L	O
		OSHW-300F	300 L	O
		OSHW-500F	500 L	O
	DHW tanks (Double coil)	OSHW-300FD	300 L	O
	DHW tank kit	PHLTA	For Split	X
		PHLTB	For Monobloc	X
	DHW sensor ****	PHRSTA0	-	O
	Mixing valve	OSHA-MV	3/4" DN20	X
		OSHA-MV1	1" DN20	X
	3way valve	OSHA-3V	-	O
	Solar thermal kit	PHLLA	-	X
	2nd Circuit Thermistor	PRSTAT5K10	-	X
	Backup heater	AHEH036A [HA031M E1]	220-240 V, 1Φ	X
		AHEH066A [HA061M E1]		
	Drain pan	PHDPB	-	X

**Note**

- O: Possible, X: Impossible, - : Not applicable, Embedded : Included with product.
- \* : Some advanced functions controlled by individual controller cannot be operated.
- \*\* : It could not be operated some functions.
- If you need more detail, please refer to the **BECON** PDB or the manual of product. (<http://partner.lge.com/global> : Home> Doc.Library> Product > Control(BECON))

\*\*\* Meter interface cannot be connected at the same time with 3rd-party controller.

\*\*\*\* Included in the Accessory kit of the indoor unit

## 2. Specifications

Indoor Unit				AHNW166T3 [HN1610H NK3]
Operation Range (Leaving Water Temperature)	Heating, DHW	Min. ~ Max.	°C DB	25 - 80
Compressor	Type			Hermetic Sealed Twin Rotary
	Model	Model × No.		EPT525MBA × 1
	Motor Type			BLDC
	Displacement	cm <sup>3</sup> /Rev.		52.5
Heat Exchanger	Water Circuit	Type	-	Brazed Plate HEX
		Quantity	EA	1
		Number of Plate	EA	76
		Water Volume	ℓ	1.0
	Refrigerant Circuit	Type	-	Brazed Plate HEX
		Quantity	EA	1
Number of Plate		EA	50	
Refrigerant	Type			R134a
	GWP (Global Warming Potential)			1,430.0
	Precharged Amount	g		1,800
	t-CO <sub>2</sub> eq.			2.574
	Control			Electronic Expansion Valve
Refrigerant Oil	Type			FVC68D
	Charged Volume	cc × No.		1,300
Rated Water Flow	Rated (Min. ~ Max.)		ℓ/min	46 (15 - 70)
Head loss			kPa	30.68
Devices for Water Circuit			-	Flow Switch
Piping Connections	Water Circuit	Inlet	mm(Inch)	Male PT 25.4(1)
		Outlet	mm(Inch)	Male PT 25.4(1)
	Refrigerant Circuit	Gas	mm(Inch)	Φ 15.88 (5/8)
		Liquid	mm(Inch)	Φ 9.52 (3/8)
Sound Power Level	Heating (Cooling Fan Off)	Rated	dB(A)	58
	Heating (Cooling Fan On)	Rated	dB(A)	63
Sound Pressure Level (at 1m)	Heating	Rated	dB(A)	50
Dimensions	Unit	W × H × D	mm	520 x 1,080 x 330
	Packed Unit	W × H × D	mm	682 x 1,168 x 423
Weight	Unit			kg
	Packed Unit			kg

**Note**

1. Due to our policy of innovation some specifications may be changed without notification.
2. Wiring cable size must comply with the applicable local and national codes. And "Electric characteristics" chapter should be considered for electrical work and design. Especially the power cable and circuit breaker should be selected in accordance with that.
3. Sound Level Values are measured at Noise Measuring chamber accordance with standard. Therefore, these values depend on the ambient conditions and values are normally higher in actual operation
4. Performances are based on the following conditions (It is according to EN14511):
  - Heating : Inlet/Outlet Water Temp. 30°C/ 35°C, Outdoor Temp. 7°CDB / 6°CWB
  - Interconnected Pipe Length is 5m and difference of Elevation (Outdoor ~ Indoor Unit) is 0m.
5. This product contains Fluorinated greenhouse gases.

## 2. Specifications

Electrical Specification			AHNW166T3 [HN1610H NK3]
Power Supply		V, Ø, Hz	220-240, 1, 50
Maximum Power Input		W	4,750
Maximum Running Current		A	20.2
Wiring Connections	Power Cable (H07RN-F) (Included Earth)	mm <sup>2</sup> x cores	4.0 x 3
	Communication Cable (VCTF-SB) (included Earth)	mm <sup>2</sup> x cores	1.0~1.5 x 2

Accessory kit of the indoor unit			AHNW166T3 [HN1610H NK3]
Remote Controller		-	RS3
Water Tank Temperature Sensor with Holder	Sensor size	Ø	7
	Resistance	kΩ	5
Strainer	Mesh size	-	28 mesh
	Material	-	Stainless Steel

**Note**

1. Due to our policy of innovation some specifications may be changed without notification.
2. Wiring cable size must comply with the applicable local and national codes. And “Electric characteristics” chapter should be considered for electrical work and design. Especially the power cable and circuit breaker should be selected in accordance with that.
3. Sound Level Values are measured at Noise Measuring chamber accordance with standard. Therefore, these values depend on the ambient conditions and values are normally higher in actual operation
4. Performances are based on the following conditions (It is according to EN14511):
  - Heating : Inlet/Outlet Water Temp. 30°C/ 35°C, Outdoor Temp. 7°CDB / 6°CWB
  - Interconnected Pipe Length is 5m and difference of Elevation (Outdoor ~ Indoor Unit) is 0m.
5. This product contains Fluorinated greenhouse gases.

### 3. Dimensions

#### 3.1 Internal

[Unit: mm]  
 Chassis code : K3  
 P/No. : TBW35843601\_rev.01

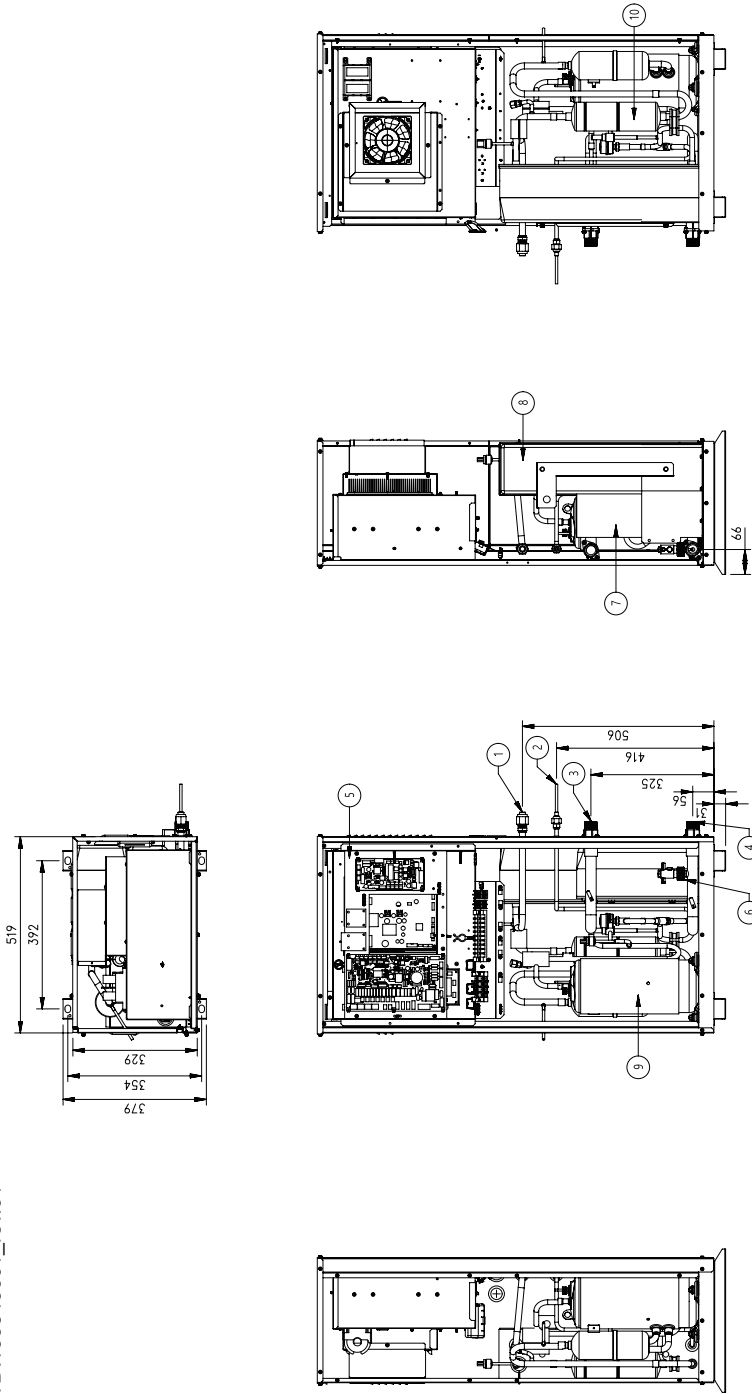

10	Accumulator	716 cc
9	Compressor	EPT525MBA
8	Plate Heat Exchanger	Heat exchanger between refrigerant and refrigerant
7	Plate Heat Exchanger	Heat exchanger between refrigerant and water
6	Flow Switch	Minimum operation range : 15 LPM
5	Control Box	PCB and Terminal blocks
4	Entering Water Pipe	Male PT 25 mm (1 inch)
3	Leaving Water Pipe	Male PT 25 mm (1 inch)
2	Refrigerant Pipe	Ø 9.52
1	Refrigerant Pipe	Ø 15.88
No.	Part Name	Description

**Note**  
 1. Unit should be installed in compliance with the installation manual in the product box.  
 2. Unit should be grounded in accordance with the local regulations or applicable national codes.  
 3. All electrical components and materials to be supplied from the site must comply with the local regulations or international codes.

### 3. Dimensions

#### 3.2 External

[Unit: mm]  
 Chassis code : K3  
 P/No. : TBW35843601\_rev.01

Technical drawings of the Hydro Box Unit showing front, side, and top views with dimensions and callouts. The front view shows a width of 1080 mm and a height of 520 mm. The side view shows a depth of 330 mm. The top view shows a length of 656 mm and a width of 379 mm. Callouts 1 through 6 indicate the locations of the refrigerant pipe, water pipes, and cable holes.

**Note**

1. Unit should be installed in compliance with the installation manual in the product box.
2. Unit should be grounded in accordance with the local regulations or applicable national codes.
3. All electrical components and materials to be supplied from the site must comply with the local regulations or international codes.

No.	Part Name	Ø
6	Power Cable Hole	Ø 30
5	Connection Cable Hole	Ø 30
4	Entering Water Pipe	Male PT 25 mm (1 inch)
3	Leaving Water Pipe	Male PT 25 mm (1 inch)
2	Refrigerant Pipe	Ø 9.52
1	Refrigerant Pipe	Ø 15.88
	Description	



# 4. Wiring diagrams

## ■ AHNW166T3 [HN1610H NK3]

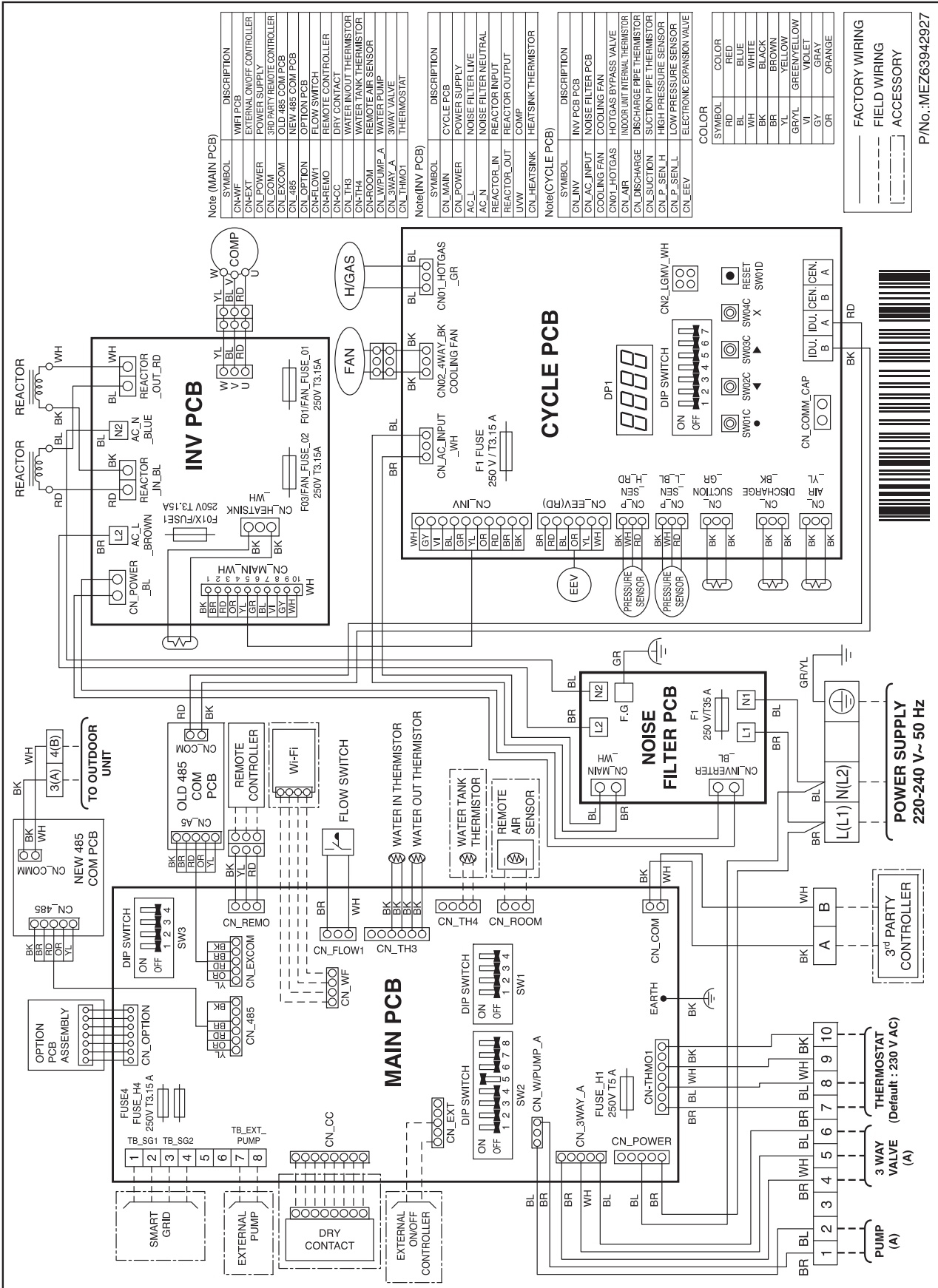

## 4. Wiring diagrams

---

### **Note**

- THERMOSTAT : External Room air thermostat (230 VAC)
    - 7 = Power line to thermostat
    - 8 = Neutral line to thermostat
    - 10 = Heating signal from thermostat to heat pump
  - TB\_EXT\_PUMP : External water pump
  - TB\_SG1&2 (230 VAC Input) : Signal from Photovoltaic controller (refer to Installer manual)
  - 3WAY VALVE(A) : DHW valve (230 VAC; SPDT)
    - 4 = Water tank heating
    - 5 = Room heating
    - 6 = neutral
  - 3rd PARTY CONTROLLER : Bus line(e.g. Energy metering module)
-

# 5. Piping diagrams

## ■ AHNW166T3 [HN1610H NK3]

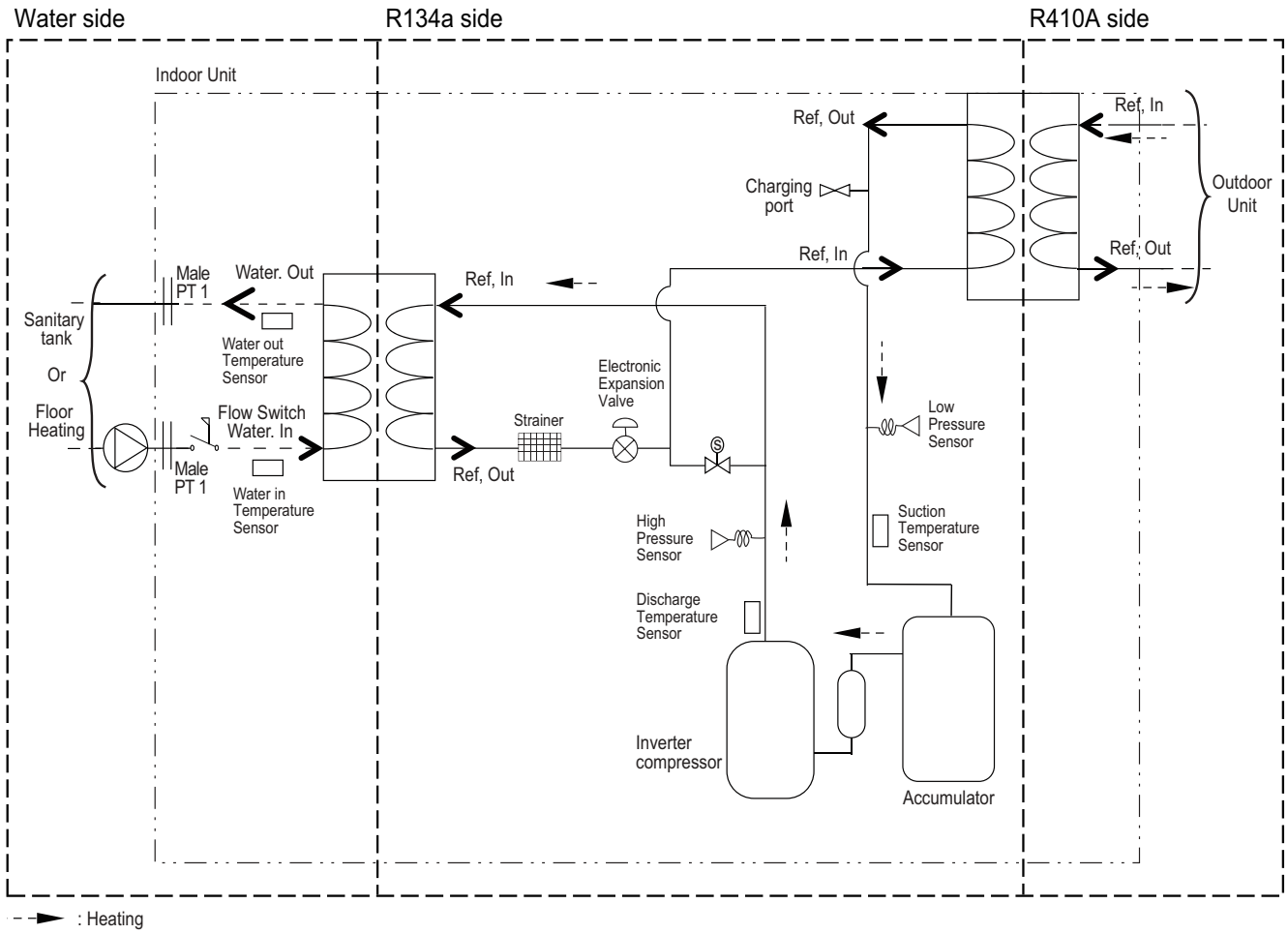

## 6. Head loss by water flow

### ■ AHNW166T3 [HN1610H NK3]

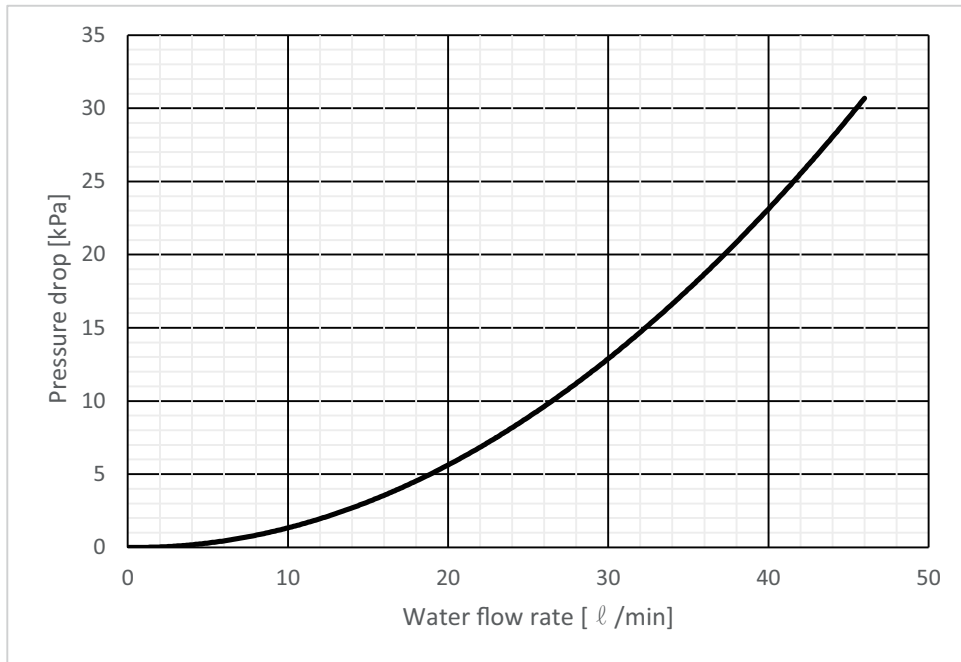



#### Note

- The table of head loss is based on test results in the unit, not a plate exchanger.

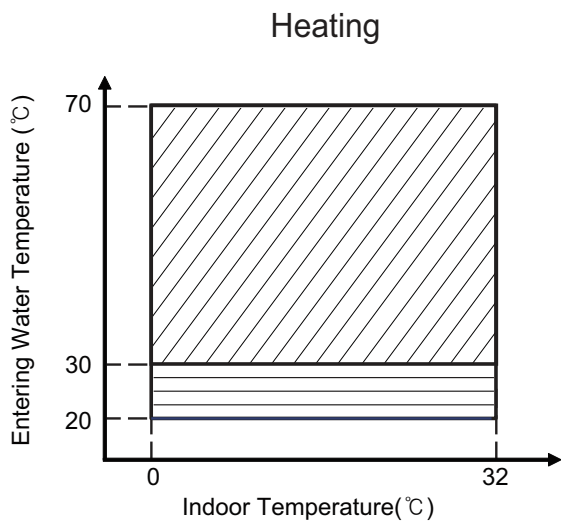

## 7. Operation range

### ■ AHNW166T3 [HN1610H NK3]

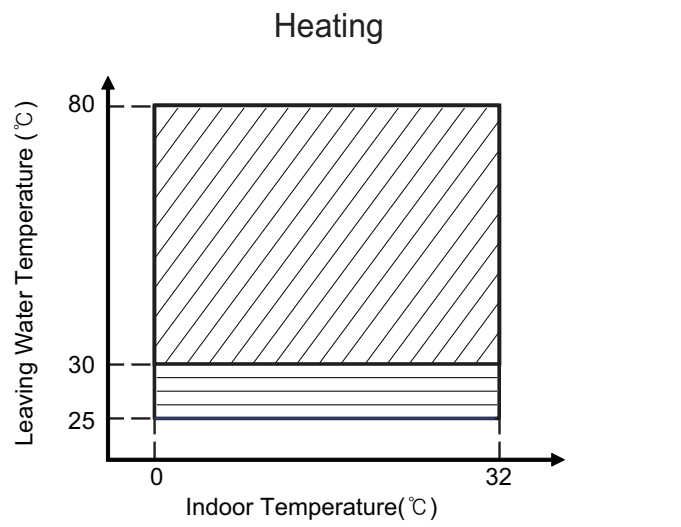

 Continuous Operation  
 Operative



 Continuous Operation  
 Operative

- The Remote control settings are only available in the continuous operation area.

# 8. Sound levels

## ■ Sound Power Level

**Note**

- 1.Data is valid at diffuse field condition.
- 2.Data is valid at nominal operation condition.  
Refer to the Model Specifications for nominal conditions(Power source and Ambient temperature, etc)
- 3.Sound level can be increased in static pressure mode or used air guide.
- 4.Sound level will vary depending on a range of factors such as the construction (acoustic absorption coefficient).
- 5.Reference acoustic intensity 0dB = 10E-6μW/m<sup>2</sup>
- 6.Sound power level is measured on the rated condition in the reverberation rooms by ISO 3741 standard.  
Therefore, these values can be increased owing to ambient conditions during operation.

Model	Sound Power Level [dB(A)]	
	Cooling Fan	
AHNW166T3 [HN1610H NK3]	OFF	ON
	58	63

**AHNW166T3 [HN1610H NK3]**

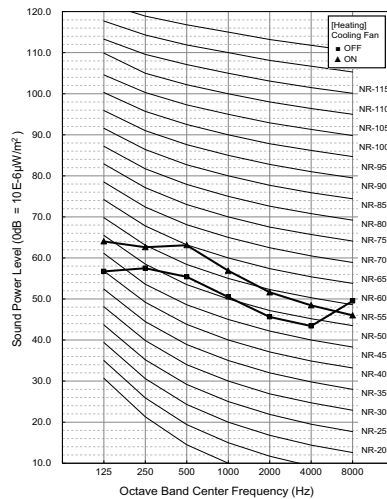

# ***THERMA V***<sup>TM</sup>

Indoor unit

## **Design and installation**

- 1. Select the Best Location**
- 2. Installation Space**
- 3. Water Piping System**
- 4. Water Control**
- 5. Dip Switch Setting**

## 1. Select the Best Location

---

Select space for installing unit, which will meet the following conditions:

- The place where the unit shall be installed inside.
- The place shall easily bear a load exceeding four times of the unit weight.
- The place where the unit shall be leveled.
- The place shall allow easy water drainage.
- The place where the unit shall be connected to the outdoor unit.
- The place where the unit is not affected by an electrical noise.
- The place where there should not be any heat source or steam near the unit.



## 2. Installation Space

### 2.1 General considerations

- The following values are the least space for installation. If any service area is needed for service according to field circumstance, obtain enough service space.

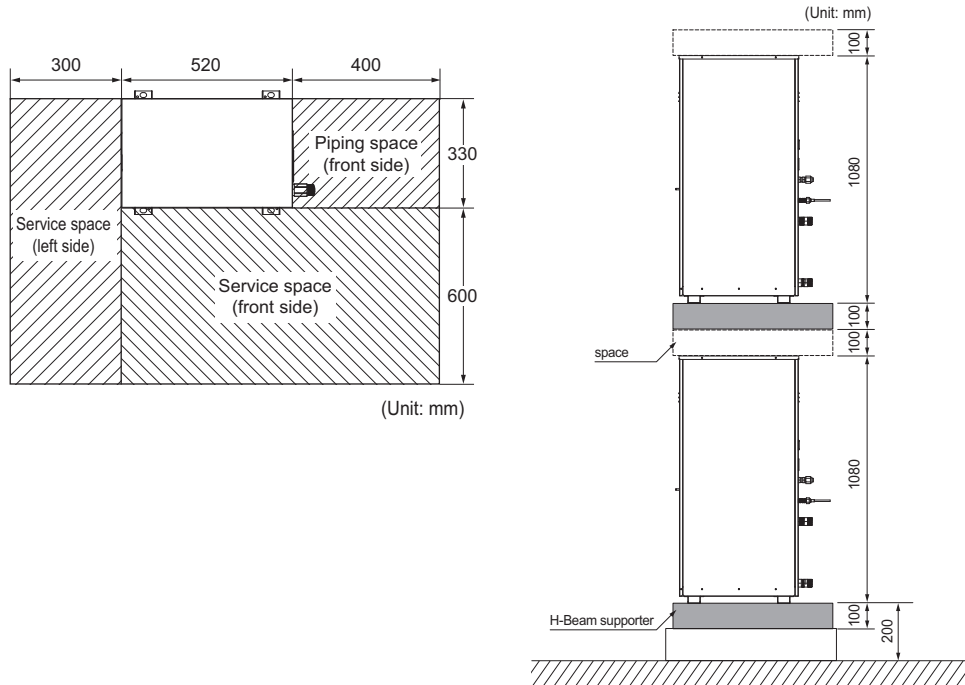

## 3. Water Piping System

### 3.1 General Considerations

Followings should be considered before beginning water circuit connection.

- Service space should be secured.
- Water pipes and connections should be cleaned using water.
- Space for installing external water pump should be provided.
- Never connect electric power while proceeding water charging.

### 3.2 Water Piping and Water Circuit Connection

While installing water pipes, followings should be considered :

- While inserting or putting water pipes, close the end of the pipe with pipe cap to avoid dust entering.
- When cutting or welding the pipe, always be careful that inner section of the pipe should not be defective. For example, no weldments or no burrs are found inside the pipe.
- Pipe fittings (e.g. L-shape elbow, T-shape tee, diameter reducer, etc) should be tightened strongly to be free from water leakage.
- Connected sections should be leakage-proof treatment by applying teflon tape, rubber bushing, sealant solution, etc.
- Appropriate tools and tooling methods should be applied to prevent mechanical breakage of the connections.
- Operation time of flow valve(e.g. 3way valve) should be less than 90 seconds.
- Pipe is insulated to prevent heat loss to external environment.

### 3.3 Water Cycle

For the water pipe system, use the closed loop type.

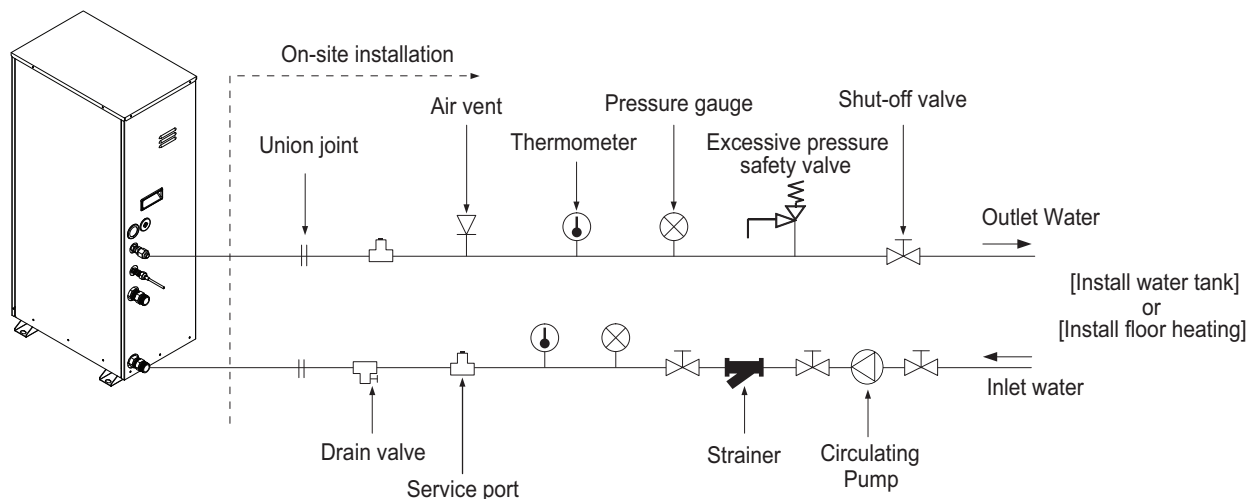

#### Note

- Always install a strainer at the inlet of the water pipe.  
For the strainer, use magnetic type with hole size less than 0.5 mm.  
(Exclude other net)

## 4. Water Control

### 4.1 Water quality

Water quality should be complied with EN 98/83 EC Directives.

#### CAUTION

- If the product is installed at existing hydraulic water loop, it is important to clean hydraulic pipes to remove sludge and scale.
- Installing sludge strainer in the water loop is very important to prevent performance degrade.
- Chemical treatment to prevent rust should be performed by installer.
- It is strongly recommended to install an additional filter on the heating water circuit. Especially to remove metallic particles from the heating piping, it is advised to use a magnetic or cyclone filter, which can remove small particles. Small particles may damage the unit and will NOT be removed by the standard filter of the heat pump system.
- Water quality check should be implemented before completing the installation of system.  
Detailed guide can be found in the table as below.

Water contents	Value			
pH	7.5~9.0			
Conductivity	10~500 uS/cm			
TDS (Total dissolved solids)	8~400 ppm			
Alkalinity (HCO <sub>3</sub> <sup>-</sup> )	60~300 (mg/L)			
Total hardness	4 ~ 8.5 °dH			
	71.4 ~ 151.7 (mg/L)			
Iron (Fe)	≤ 0.2 (mg/L)			
Sulphate (SO <sub>4</sub> <sup>2-</sup> )	≤ 100 (mg/L)			
Nitrite (NO <sub>3</sub> <sup>-</sup> )	≤ 100 (mg/L)			
Free chlorine (Cl <sub>2</sub> )	≤ 1 (mg/L)			
Chlorides (Cl <sup>-</sup> )	ppm		STS316	STS304
	pH7	15 °C	3,000	180
		40 °C	500	50
		60 °C	200	30
		80 °C	125	20
	pH9	15 °C	18,000	700
		40 °C	2,600	250
		60 °C	1,000	170
80 °C		550	130	

## 4. Water Control

### 4.2 Frost protection

In areas of the country where entering water temperatures drop below 0 °C, the water pipe must be protected by using an approved antifreeze solution. Consult your heat pump unit supplier for locally approved solutions in your area.

Calculate the approximate volume of water in the system. And add the water volume contained in the heat pump to this total volume.

Antifreeze type	Antifreeze mixing ratio (by volume)					
	0°C	-5°C	-10°C	-15°C	-20°C	-25°C
Methanol	0%	6%	12%	16%	24%	30%
Ethylene glycol	0%	12%	20%	30%	-	-
Propylene glycol	0%	17%	25%	33%	-	-

#### CAUTION

- Use only one of the above antifreeze.
- If a antifreeze is used, pressure drop and capability degradation of the system can be occurred.
- If one of antifreezes is used, corrosion can be occurred. So please add corrosion inhibitor.
- Please check the concentration of the antifreeze periodically to keep same concentration.
- When the antifreeze is used (for installation or operation), take care to ensure that antifreeze must not be touched.
- Ensure to respect all laws and norms of your country about antifreeze usage.

## 4. Water Control

### 4.3 Capacity correction factor by antifreeze

Antifreeze Type	Item	Antifreeze % by wt				
		10%	20%	30%	40%	50%
Methanol	Cooling	0.998	0.997	0.995	0.993	0.992
	Heating	0.995	0.990	0.985	0.979	0.974
	Pressure Drop	1.023	1.057	1.091	1.122	1.160
Ethylene glycol	Cooling	0.996	0.991	0.987	0.983	0.979
	Heating	0.993	0.985	0.977	0.969	0.961
	Pressure Drop	1.024	1.068	1.124	1.188	1.263
Propylene glycol	Cooling	0.993	0.987	0.980	0.974	0.968
	Heating	0.966	0.973	0.960	0.948	0.935
	Pressure Drop	1.040	1.098	1.174	1.273	1.405

#### ◆ Correction factor of cooling capacity

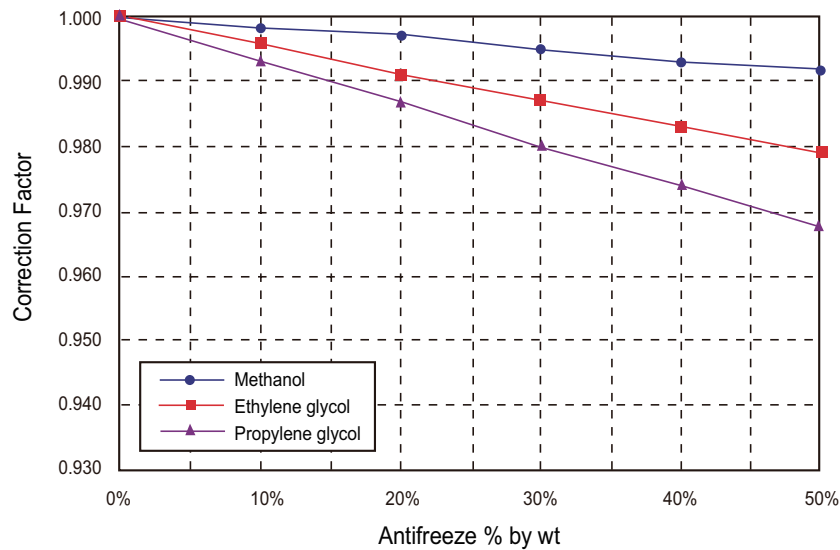

#### ◆ Correction factor of heating capacity

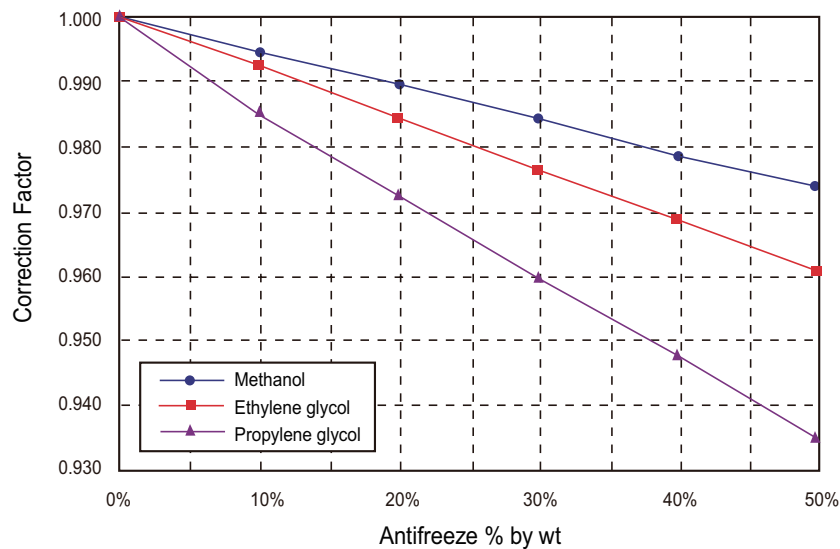

## 5. Dip Switch Setting

### 5.1 Information

Turn off electric power supply before setting DIP switch





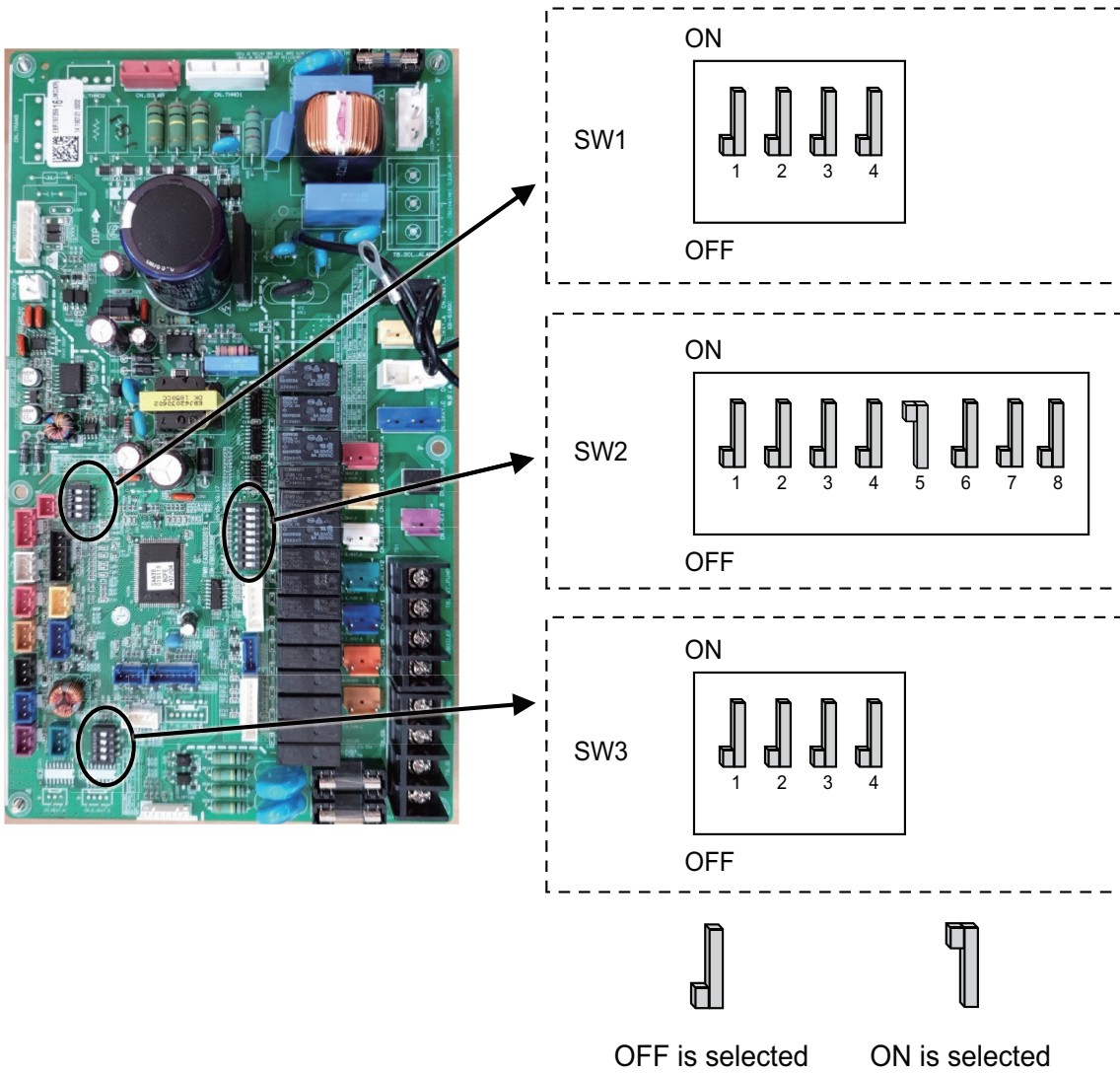







- Whenever adjusting DIP switch, turn off electric power supply to avoid electric shock.

#### ■ Indoor PCB















## 5. Dip Switch Setting

### ◆ Option Switch 1

Description	Setting	Default
MODBUS Communication Type	1  As Master (LG extension modules)	1 
	1  As Slave (3rd party controller)	
Unused	2   Unused	2 
Unused	3   Unused	3 
Unused	4   Unused	4 























### ◆ Option Switch 3

Description	Setting	Default
Remote Room air sensor (Accessory)	1  Remote sensor is not installed	1 
	1  Remote sensor is installed	
Antifreeze agent	2  Antifreeze agent is not used	2 
	2  Antifreeze agent is used *	
Unused	3   Unused	3 
Unused	4   Unused	4 

\* Possibility to allow colder water temperature by setting.  
 Bridge at CN\_FLOW2 on Hydro-PCB must be dis-connected to enable setting.

## 5. Dip Switch Setting

### ◆ Option Switch 2

Description	Setting	Default
Role when central controller is equipped	1  As Master	1 
	1  As Slave	
Accessory installation information	  Unit + Outdoor unit is installed	 
	  Unit + Outdoor unit + DHW tank is installed	
	  DHW tank Only	
Cycle	4  Heating Only	4 
Flow Switch Detection	5  Always	5 
	5  While water pump is on	
Selecting electric heater capacity	  Electric heater is not used	 
Thermostat installation information	8  Thermostat is NOT installed	8 
	8  Thermostat is installed	



# ***THERMA V***<sup>TM</sup>

## Split Type

### **Outdoor unit**

- 1. List of functions**
- 2. Specification**
- 3. Dimensions**
- 4. Wiring Diagram**
- 5. Piping Diagram**
- 6. Performance Data**
- 7. Operation Range**
- 8. Electric Characteristics**
- 9. Sound Levels**

# 1. List of functions

## Basic functions of Unit

Category	Functions	AHUW166T3 [HU161HA U33]
Reliability	Defrost / Deicing	O
	High pressure switch	X
	Low pressure switch	X
	Phase protection	X
	Restart delay (3-minutes)	O
	Self diagnosis	O
	Soft start	X
Convenience	Test function	X
	Wiring Error Check	O
	Peak Control	X
	Mode Lock	X
	Low Noise Operation	X
	Forced Cooling Operation (Outdoor Unit)	X
Network function	Network solution(LGAP)	O

**Note**

1. O : Applied, X : Not applied

Accessory : Ordered and purchased separately the accessory package referring to the model name provided and install at field.

Accessory line-ups varies by region, so check your local catalogue or local sales material.

## Accessory Compatibility List

Category	Product	Remark	AHUW166T3 [HU161HA U33]	
Central Controller	AC EZ	PQCSZ250S0	AC EZ	X
	AC Ez Touch	PACEZA000	AC Ez Touch	O
	AC Smart	PACS4B000	AC Smart IV	O
		PACS5A000	AC Smart 5	O
	ACP	PACP4B000	ACP IV	O
		PACP5A000	ACP 5	O
AC Manager **	PACM5A000	AC Manager 5	O	
Gateway	IDU PI485	PHNFP14A0	Without case	X
		PSNFP14A0	With case	X
	ODU PI485	PMNFP14A1	PI 485 Gateway	O
	BACnet	PQNFB17C0	ACP BACnet	O
	Lonworks	PLNWKB000	ACP Lonworks	O
Modbus RTU	PMBUSB00A	-	O	
ETC	PDI	PPWRDB000	PDI Standard	O
		PQNUD1S40	PDI Premium	O
	ACS IO Module	PEXPMB000	-	X

**Note**

1. O: Possible, X: Impossible, - : Not applicable

2. \* : Some advanced functions controlled by individual controller cannot be operated.

3. \*\* : ACP or AC Smart is needed.

4. If you need more detail, please refer to the manual of product.

(<http://partner.lge.com/global> : Home> Doc.Library> Product > Control(BECON))

## 2. Specifications

Nominal Capacity and Nominal Input				AHUW166T3 [HU161HA U33]
Category	Outdoor Temp. (°C) DB / WB	Leaving Water Temp. (°C)	-	
Capacity	7 / 6	35	kW	16.0
		55	kW	14.0
Power Input	7 / 6	35	kW	4.89
		55	kW	5.00
COP	7 / 6	35	W/W	3.27
		55	W/W	2.78
SCOP (Low temp. Average climate)*				3.23
SCOP (High temp. Average climate)*				3.01
Rated Water Flow Rate (at LWT 35°C)			LPM	46.00

Outdoor Units				AHUW166T3 [HU161HA U33]	
Operation Range (Outdoor Temperature)	Heating	Min. ~ Max.	°C DB	-25 ~ 35	
Compressor	Type	-		Hermetic Sealed Scroll	
	Model	Model × No.		RJB036MAA × 1	
	Motor Type	-		BLDC	
	Displacement	cm <sup>3</sup> /Rev.		31.6	
Refrigerant	Type	-		R410A	
	GWP (Global Warming Potential)	-		2,078.5	
	Precharged Amount	g		3,800	
	t-CO <sub>2</sub> eq.	-		7.933	
	Control	-		Electronic Expansion Valve	
Refrigerant Oil	Type	-		FVC68D	
	Charged Volume	cc × No.		1,100	
Piping Connections	Gas	mm(Inch)		Φ 15.88 (5/8)	
	Liquid	mm(Inch)		Φ 9.52 (3/8)	
	Piping Length	Standard	m		7.5
		Max.	m		50
	Piping Level Difference	Max.		m	30
	Chargeless-Pipe Length	m		7.5	
	Additional Charging Volume	g/m		40	
Heat Exchanger	Type	-		Fin & Tube	
	Quantity	EA		2	
	Row x Column x FPI	-		2 x 32 x 14	
Fan	Type	-		Propeller	
	Air Flow Rate	Rated	m <sup>3</sup> /min × No.	60.0 × 2	
Fan Motor	Type	-		BLDC	
	Output	W × No.		124 × 2	

**Note**

- Due to our policy of innovation some specifications may be changed without notification.
- Wiring cable size must comply with the applicable local and national codes. And "Electric characteristics" chapter should be considered for electrical work and design. Especially the power cable and circuit breaker should be selected in accordance with that.
- Sound Level Values are measured at Noise Measuring chamber accordance with standard. Therefore, these values depend on the ambient conditions and values are normally higher in actual operation
- Performances are based on the following conditions (It is according to EN14511):
  - Heating : Inlet/Outlet Water Temp. 30°C/ 35°C, Outdoor Temp. 7°CDB / 6°CWB
  - Interconnected Pipe Length is 5m and difference of Elevation (Outdoor ~ Indoor Unit) is 0m.
- This product contains Fluorinated greenhouse gases.

\* : This values are accordance with EN14825.

## 2. Specifications

Electrical Specifications			AHUW166T3 [HU161HA U33]
Power Supply		V, Ø, Hz	220-240, 1, 50
Maximum Power Input		W	4,445
Maximum Running Current		A	18.9
Peak Control Running Current		A	-
Rated Running Current		A	8.4
Wiring Connections	Power Supply Cable (H07RN-F) (included Earth)	mm <sup>2</sup> x cores	4.0 x 3

Technical Specifications				AHUW166T3 [HU161HA U33]
Sound Power Level	Heating	Rated	dB(A)	63
Sound Pressure Level (at 1m)	Heating	Rated	dB(A)	55
Dimensions	Unit	W x H x D	mm	950 x 1,380 x 330
	Packed Unit	W x H x D	mm	1,140 x 1,553 x 466
Weight	Unit		kg	89.0
	Packed Unit		kg	102.0

**Note**

1. Due to our policy of innovation some specifications may be changed without notification.
2. Wiring cable size must comply with the applicable local and national codes. And "Electric characteristics" chapter should be considered for electrical work and design. Especially the power cable and circuit breaker should be selected in accordance with that.
3. Sound Level Values are measured at Noise Measuring chamber accordance with standard. Therefore, these values depend on the ambient conditions and values are normally higher in actual operation
4. Performances are based on the following conditions (It is according to EN14511):
  - Heating : Inlet/Outlet Water Temp. 30°C/ 35°C, Outdoor Temp. 7°CDB / 6°CWB
  - Interconnected Pipe Length is 5m and difference of Elevation (Outdoor ~ Indoor Unit) is 0m.
5. This product contains Fluorinated greenhouse gases.

# 3. Dimensions

## AHUW166T3 [HU161HA U33]

[Unit: mm]

Chassis code : U60A  
P/No. : TBW35846801\_rev.01

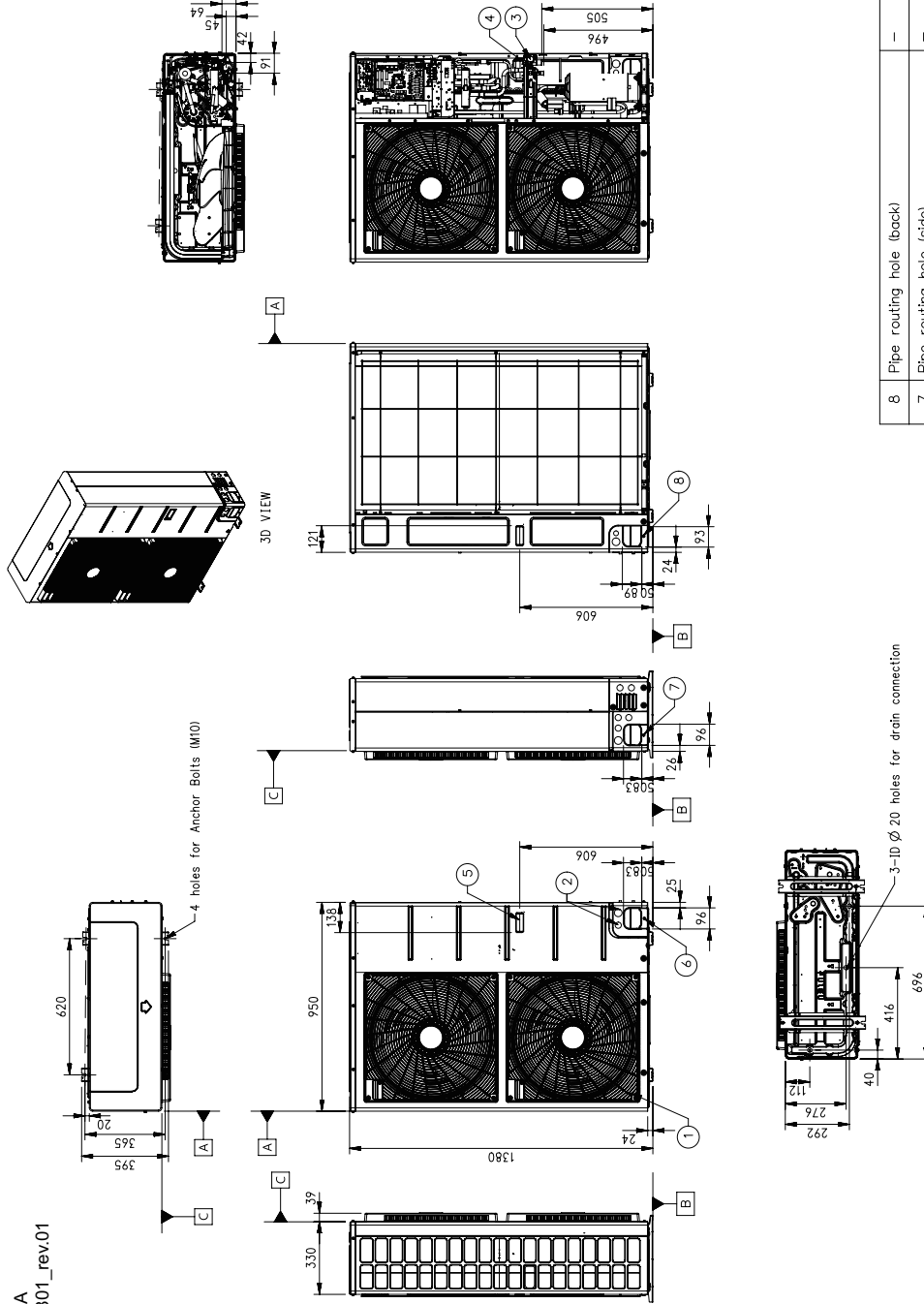

**Note**

1. Unit should be installed in compliance with the installation manual in the product box.
2. Unit should be grounded in accordance with the local regulations or applicable national codes.
3. Grounding components to be supplied from the site must comply with the local regulations or international codes.
4. Electrical characteristics chapter should be considered for electrical work and design. Especially the power cable and circuit breaker should be selected in accordance with that.

No.	Part Name	Description
8	Pipe routing hole (back)	-
7	Pipe routing hole (side)	-
6	Pipe routing hole (front)	-
5	Handle	-
4	Liquid Pipe Connection	Flare Joint
3	Gas Pipe Connection	Flare Joint
2	Power and Communication Cable Hole	-
1	Air Outlet	-

# 4. Wiring diagrams

## AHUW166T3 [HU161HA U33]

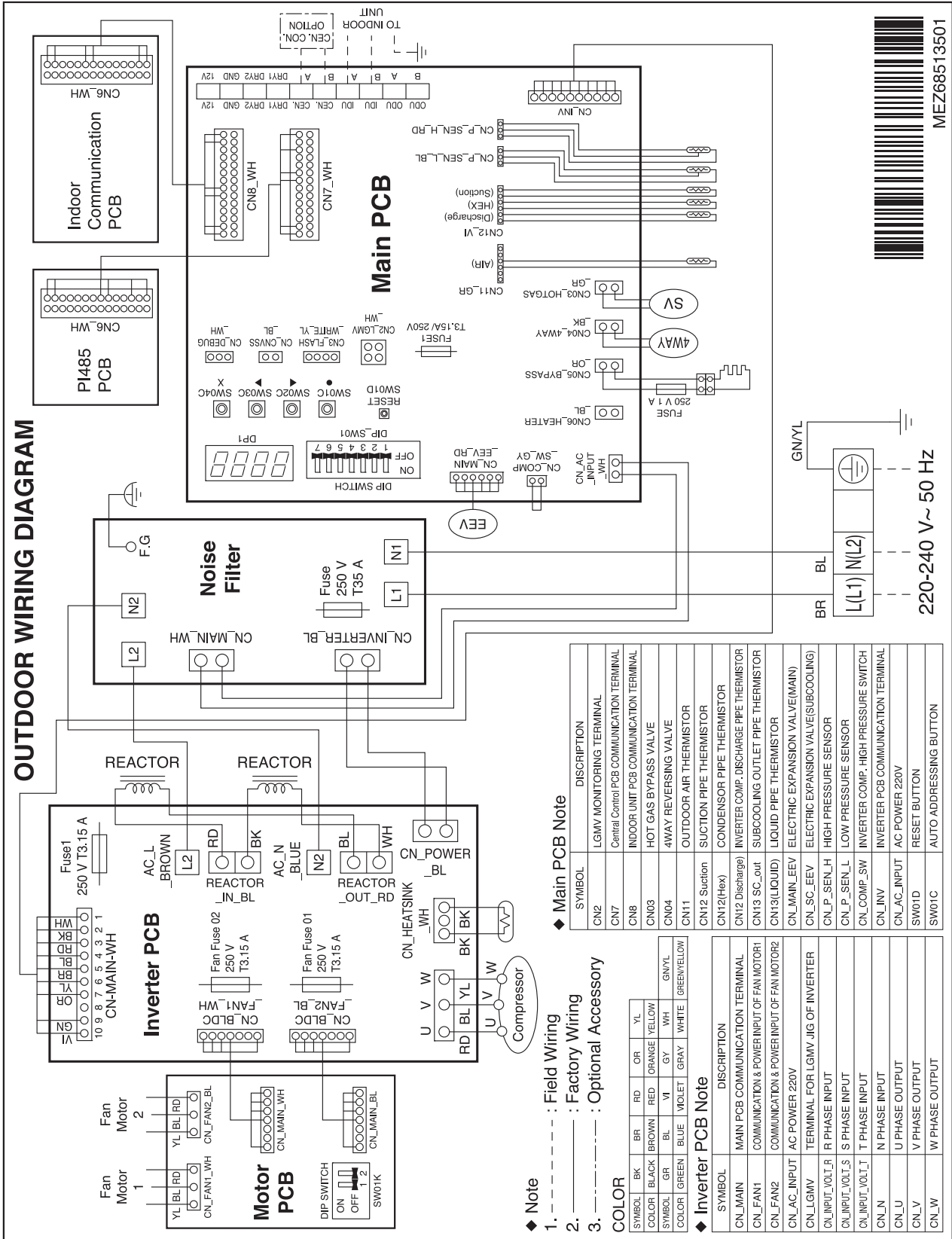

MEZ68513501

220-240 V ~ 50 Hz

# 5. Piping diagrams

## ■ AHUW166T3 [HU161HA U33]

Outdoor Unit

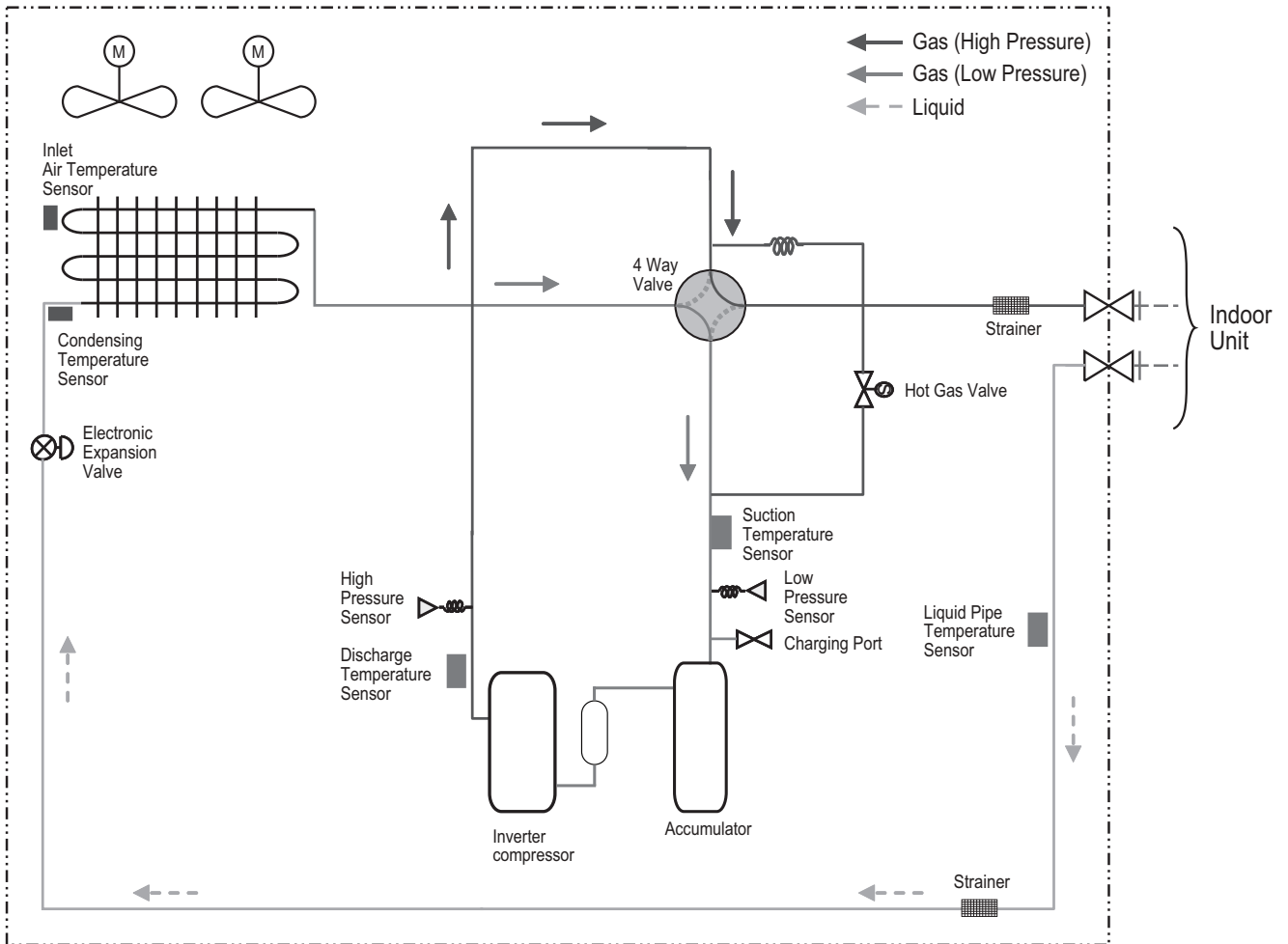

## 6. Performance Data

### 6.1 Heating Operation

#### ■ Maximum Heating Capacity (Included defrost effect)

Outdoor Temperature [°C DB]	Water flow rate 46.0 LPM							
	LWT 35 °C		LWT 40 °C		LWT 45 °C		LWT 50 °C	
	TC	COP	TC	COP	TC	COP	TC	COP
-25	13.50	2.30	13.29	2.20	13.07	2.10	12.86	2.00
-20	14.19	2.45	14.04	2.42	13.88	2.31	13.73	2.20
-15	14.89	2.60	14.79	2.65	14.70	2.52	14.60	2.40
-7	16.00	3.15	16.00	3.01	16.00	2.86	16.00	2.72
-4	16.00	3.18	16.00	3.12	16.00	2.97	16.00	2.81
-2	16.00	3.20	16.00	3.20	16.00	3.04	16.00	2.88
2	16.00	3.25	16.00	3.35	16.00	3.18	16.00	3.00
7	16.00	3.27	16.00	3.54	16.00	3.35	16.00	3.16
10	16.00	3.44	16.00	3.66	16.00	3.45	16.00	3.25
15	16.00	3.74	16.00	3.85	16.00	3.63	16.00	3.41
18	16.00	3.91	16.00	3.96	16.00	3.73	16.00	3.50
20	16.00	4.03	16.00	4.04	16.00	3.80	16.00	3.56
35	16.00	4.90	16.00	4.61	16.00	4.32	16.00	4.03

Outdoor Temperature [°C DB]	Water flow rate 28.8 LPM				Water flow rate 23.0 LPM							
	LWT 55 °C		LWT 60 °C		LWT 65 °C		LWT 70 °C		LWT 75 °C		LWT 80 °C	
	TC	COP	TC	COP	TC	COP	TC	COP	TC	COP	TC	COP
-25	12.64	1.90	12.43	1.80	12.21	1.70	12.00	1.60				
-20	13.58	2.05	13.42	1.98	13.27	1.86	13.11	1.75	12.96	0.56		
-15	14.51	2.21	14.41	2.15	14.32	2.03	14.22	1.90	14.10	1.11	14.00	1.72
-7	16.00	2.45	16.00	2.43	16.00	2.29	16.00	2.15	16.00	2.00	16.00	1.86
-4	16.00	2.54	16.00	2.51	16.00	2.35	16.00	2.20	16.00	2.05	16.00	1.89
-2	16.00	2.60	16.00	2.56	16.00	2.39	16.00	2.23	16.00	2.07	16.00	1.91
2	16.00	2.73	16.00	2.65	16.00	2.48	16.00	2.30	16.00	2.13	16.00	1.95
7	16.00	2.79	16.00	2.77	16.00	2.58	16.00	2.39	16.00	2.20	16.00	2.18
10	16.00	2.97	16.00	2.85	16.00	2.64	16.00	2.44	16.00	2.24	16.00	2.04
15	16.00	3.13	16.00	2.97	16.00	2.75	16.00	2.53	16.00	2.31	16.00	2.09
18	16.00	3.22	16.00	3.04	16.00	2.81	16.00	2.58	16.00	2.35	16.00	2.12
20	16.00	3.28	16.00	3.09	16.00	2.85	16.00	2.62	16.00	2.38	16.00	2.14
35	16.00	3.74	16.00	3.46	16.00	3.17	16.00	2.88	16.00	2.59	16.00	2.30

**Note**

1. DB : Dry bulb temperature(°C), LWT : Leaving water temperature(°C), LPM : Liters per minute (ℓ/min)
2. TC : Total capacity(kW), COP : Coefficient of performance (kW/kW)
3. Direct interpolation is permissible. Do not extrapolate.
4. Measuring procedure follows EN14511.
  - Rated values are based on standard conditions, and it can be found on specifications.
  - Above table values may not be matched according to installation condition. Except for rated value, the performance is not guaranteed.
  - In accordance with the test standard(or nations), the results may vary.



## 7. Operation range

### ■ AHUW166T3 [HU161HA U33]

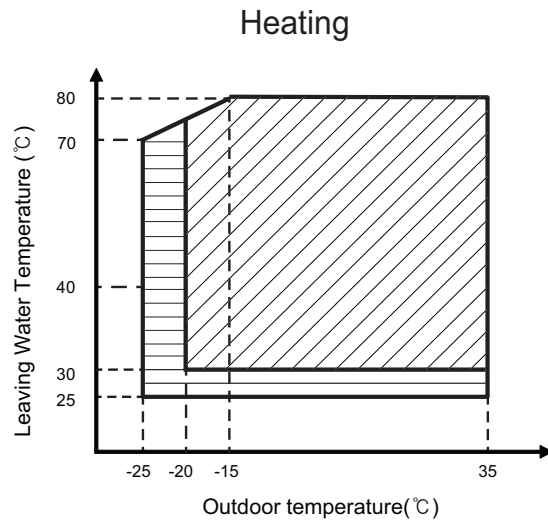
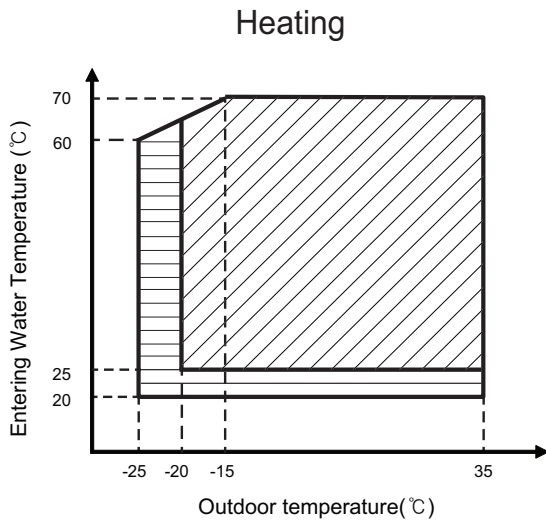

Continuous Operation  
 Operative

Continuous Operation  
 Operative

- The Remote control settings are only available in the continuous operation area.

## 8. Electric characteristics

### ■ Wiring of Main Power Supply and Equipment Capacity

1. Use a separate power supply for the Outdoor Unit and Backup Heater.
2. Bear in mind ambient conditions (ambient temperature, direct sunlight, rain liquid, etc.) when proceeding with the wiring and connections
3. The wire size is the minimum value for metal conduit wiring. The power cord size should be 1 rank thicker taking into account the line voltage drops. Make sure the power-supply voltage does not drop more than 10%.
4. Specific wiring requirements should adhere to the wiring regulations of the region.
5. Power supply cords of parts of appliances for outdoor use should not be lighter than polychloroprene sheathed flexible cord.
6. Don't install an individual switch or electrical outlet to disconnect the indoor unit separately from the power supply.

### ⚠ WARNING

- Follow ordinance of your governmental organization for technical standard related to electrical equipment, wiring regulations and guidance of each electric power company.
- Make sure to use specified wires for connections so that no external force is imparted to terminal connections. If connections are not fixed firmly, it may cause heating or fire.
- Make sure to use the appropriate type of overcurrent protection switch. Note that generated overcurrent may include some amount of direct current.

### ⚠ CAUTION

- All installation site must require attachment of an earth leakage breaker. If no earth leakage breaker is installed, it may cause an electric shock.
- Do not use anything other than breaker and fuse with correct capacity. Using fuse and wire or copper wire with too large capacity may cause a malfunction of unit or fire.

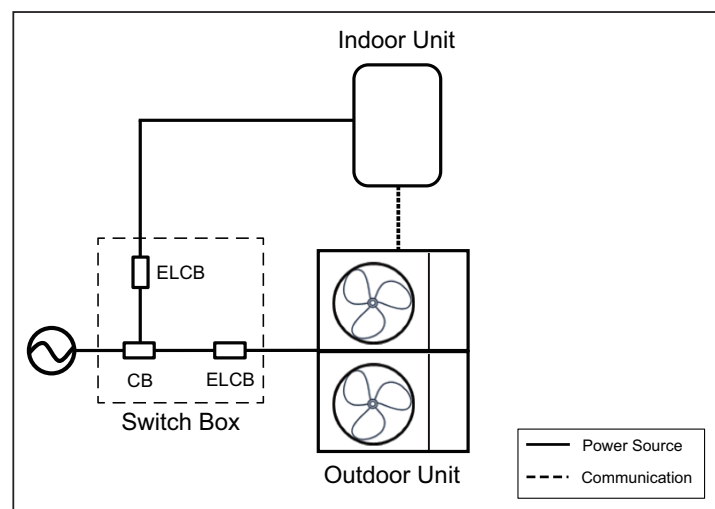

Outdoor Unit	Indoor Unit	Hz	Volts	Voltage Range
AHUW166T3 [HU161HA U33]	AHNW166T3 [HN1610H NK3]	50	220-240	Max : 264 Min : 198

# 9. Sound levels

## ■ Sound Power Level

**Note**

- 1.Data is valid at diffuse field condition.
- 2.Reference acoustic intensity  $0dB = 10E-6\mu W/m^2$
- 3.Sound power level is measured on the rated condition in the reverberation rooms. Refer to the Model Specifications for nominal conditions(Power source and Ambient temperature, etc)
- 4.Sound levels can be increased in accordance with installation and operating conditions.
- 5.Sound level will vary depending on a range of factors such as the construction (acoustic absorption coefficient) of particular installed place in which the equipment in installed.
- 6.Sound power level is measured on the rated condition in the reverberation rooms by ISO 3741 standard. Therefore, these values can be increased owing to ambient conditions during operation.

Model	Sound Power Level [dB(A)]
AHUW166T3 [HU161HA U33]	63

**AHUW166T3 [HU161HA U33]**

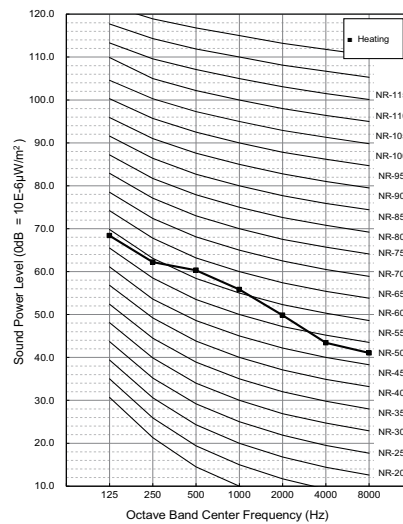

# ***THERMA V***<sup>TM</sup>

Outdoor unit

## **Design and installation**

- 1. Alternative Refrigerant R410A**
- 2. Select the Best Location**
- 3. Installation Space**
- 4. Dip Switch Setting**

## 1. Alternative Refrigerant R410A

---

- The refrigerant R410A has the property of higher operating pressure in comparison with R22. Therefore, all materials have the characteristics of higher resisting pressure than R22 ones and this characteristic should be also considered during the installation. R410A is an azeotrope of R32 and R125 mixed at 50:50, so the ozone depletion potential (ODP) of R410A is 0.
- 

### CAUTION

- **The wall thickness of the piping should comply with the relevant local and national regulations for the designed pressure 3.8MPa**
  - **Since R410A is a mixed refrigerant, the required additional refrigerant must be charged in its liquid state. If the refrigerant is charged in its gaseous state, its composition changes and the system will not work properly.**
  - **Do not place the refrigerant container under the direct rays of the sun to prevent it from exploding.**
  - **For high-pressure refrigerant, any unapproved pipe must not be used.**
  - **Do not heat pipes more than necessary to prevent them from softening.**
  - **Be careful not to install wrongly to minimize economic loss because it is expensive in comparison with R22.**
-

## 2. Select the Best Location

---

Select space for installing unit, which will meet the following conditions:

- No direct thermal radiation from other heat sources
- No possibility of annoying neighbors by noise from unit
- No exposition to strong wind
- With strength which bears weight of unit
- With space for air passage and service work shown next
- Because of the possibility of fire, do not install unit to the space where generation, inflow, stagnation, and leakage of combustible gas is expected.
- Avoid unit installation in a place where acidic solution and spray (sulfur) are often used.
- Do not use unit under any special environment where oil, steam and sulfuric gas exist.
- It is recommended to fence round the unit in order to prevent any person or animal from accessing the unit.
- If installation site is area of heavy snowfall, then the following directions should be observed.
  - Make the foundation as high as possible.
  - Fit a snow protection hood.
- Select installation location considering following conditions to avoid bad condition when additionally performing defrost operation.
  1. Install the unit at a place well ventilated and having a lot of sunshine in case of installing the product at a place with a high humidity in winter (near beach, coast, lake, etc).
  2. Performance of heating will be reduced and pre-heat time of the unit may be lengthened in case of installing the unit in winter at following location:
    - 1) Shade position with a narrow space
    - 2) Location with much humidity around.
    - 3) Location where liquid gathers since the floor is not even.
- When installing the unit in a place that is constantly exposed to a strong wind like a coast or on a high story of a building, secure a normal fan operation by using a duct or a wind shield.
  1. Install the unit so that its discharge port faces to the wall of the building. Keep a distance 300 mm or more between the unit and the wall surface.
  2. Supposing the wind direction during the operation season of the unit, install the unit so that the discharge port is set at right angle to the wind direction.

## 3. Installation Space

### 3.1 General considerations

- Install the unit so that its discharge port faces to the wall of the building. Keep a distance 500 mm or more between the unit and the wall surface.
- Supposing the wind direction during the operation season of the air conditioner, install the unit so that the discharge port is set at right angle to the wind direction.

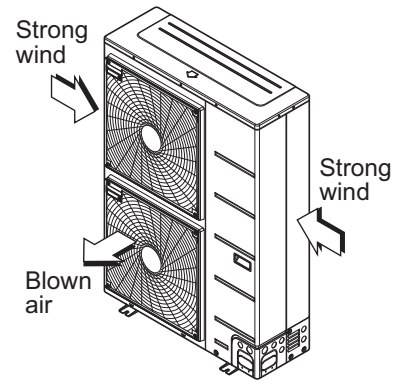
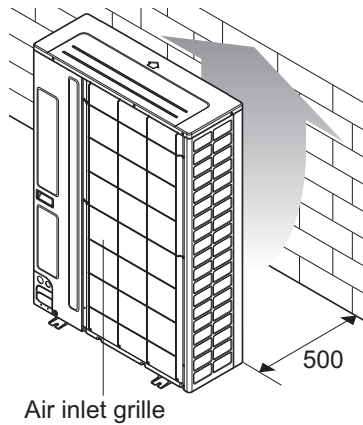

## 4. Dip Switch Setting

### 4.1 Information

Turn off electric power supply before setting DIP switch

- Whenever adjusting DIP switch, turn off electric power supply to avoid electric shock.

#### ■ Outdoor PCB

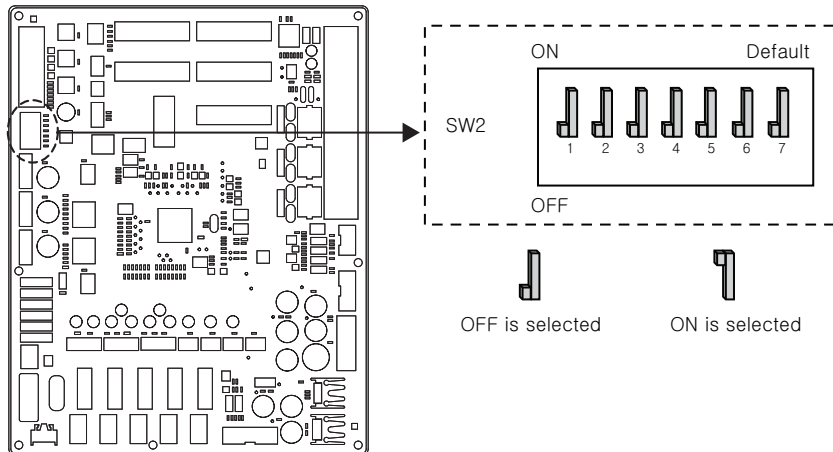





**Air Solution**

LG Electronics Inc, 128, Yeoui-daero,  
Yeongdeungpo-gu, Seoul, Korea  
(07336)  
<http://partner.lge.com>

Copyright © 2019-2021 LG Electronics Inc.  
All Rights Reserved.  
Printed in Korea January / 2021

The air conditioners manufactured by LG have received ISO9001 certificate for quality assurance and ISO14001 certificate for environmental management system.  
The specifications, designs, and information in this brochure are subject to change without notice.